

BRIGHT IDEAS.



BRIGHT INNOVATION.

**LIFT TRUCK DESIGNED WITH THE POULTRY INDUSTRY IN MIND**

**BRIGHT BULLET 81" FIELD LOADER**

**Model: B260-H-F81B**

**Approximate Weight 15,300 lbs.**



**BASIC RATED CAPACITY: 6,000 lbs. @ 24" load center / 3,600 lbs. @ 48" load center**



**BE BRIGHT - BUY RIGHT - BUY BRIGHT'S**



**LIFT TRUCK DESIGNED WITH THE POULTRY INDUSTRY IN MIND**  
**BRIGHT BULLET 81" FIELD LOADER** **Model: B260-H-F81B**

**Characteristics:**

**ENGINE:** John Deere Powertech "M" Turbocharged 4.5L with 80hp is a perfect match for the Linde® hydrostatic drive. The Tier III engine is equipped with grid heater and an overheat shut down device.

Type ..... 4 cylinders in-line  
 Gross power (@ 2500 rpm) ..... 80 HP (60 Kw)  
 Fuel tank capacity ..... 38 US gal. (144 l)  
 Hydraulic main tank capacity ..... 38 US gal. (144 l)

**TRANSMISSION:** The Linde® Automotive control series hydrostatic pump and motor drive is the perfect match to give you the most efficient machine possible. The hydrostatic system include a high quality pressure filter to increase life expectancy.

**DRIVE AXLE:** The Dana® drive with limited slip differential, Wet Disc Brake  
 • Park & Service Brake Hydraulic Controlled.

**BRAKES:** The wet disc brakes are hydraulically actuated. The parking brake is spring applied and electro-hydraulically released.

**CHASSIS:** The one-piece all steel welded construction makes a very rugged and rigid chassis. Wide and low profile frame provides a stable machine. Exceptional maintenance and service access, due to extra-wide hinged type hoods and removable covers, as well as sensible layout of major components and service points.

**MAST:** The three-stage mast is standard. The use of **Thrust Blocks** made of high strength and low friction thermoplastic material in rotator increase the life cycle. These **Thrust Blocks** can sustain greater impacts than conventional expensive to maintain roller systems. Both lift chains are of multiple-leaf construction with convenient adjustment points. The hoses for rotator are mounted inside the mast rails for maximum protection.

Hydraulic lift cylinders ..... Two 2-3/4"  
 Hydraulic rotator cylinder ..... 2-1/2"  
 Hydraulic tilt cylinders ..... Two 3-1/2"

**CARRIAGE:** The 42-3/4" wide high-capacity pin type carriage with rotator is standard. The 20° clockwise and 40° counterclockwise rotator uses the high strength and low friction **Thrust Blocks**.

**FORKS:** The pin-type forks are made from high-grade treated steel. They are pin mounted to allow for variable fork spread. The standard forks are 72" long by 4-3/4" wide and 1-3/4" thick. (optional lengths available)

**HYDRAULIC SYSTEM:** One gear type pump directly mounted on the hydrostatic pump. In-tank suction strainer and easy to replace tank top high quality return filter ensure clean oil. The sectional control valve is easily accessible and is directly controlled. The sectional and direct link control valve system makes this system the most reliable system possible.

**STEERING SYSTEM:** Hydraulic system delivers constant oil flow to hydrostatic steering system for uniform steering response. The steering cylinder is a 3-1/2". High strength link is connected directly to the steering spindles.

**DRIVE TIRES:** Front: 17.5 x 24 lug type; Rear Steering: 12.00 x 16.5 lug type

**OPERATOR'S ENCLOSURE:** The ergonomically designed operator enclosure features a complete instrument panel, a foot throttle, a forward and reverse shifter control, a main electric switch and an ergonomic seat with seat belt.

**Complete instrument panel:** Hour meter, engine temperature gauge, engine oil pressure gauge, fuel level gauge, voltmeter and air filter restriction indicator. The electrical system is protected by circuit breakers.

**Standard Features:** Electric horn, eight (8) LED working lights (4 whites and 4 reds), back up alarm.

**Overall Dimensions**

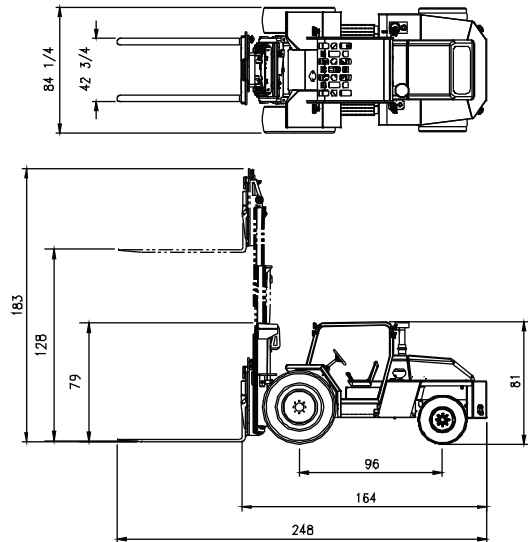

MAST GROUND CLEARANCE : 10-1/2"

N.B. The manufacturer reserves the right to make modifications at any time without incurring any obligations to make changes to machines previously manufactured.

BASIC RATED CAPACITY.....6,000 lbs. @ 24" LC  
 APPROXIMATE WEIGHT.....15,300 lbs.

**Mast Dimensions:**

LIFT CAPABILITY	OVERALL HEIGHT	
	LOWERED	RAISED
128"	79"	183"