

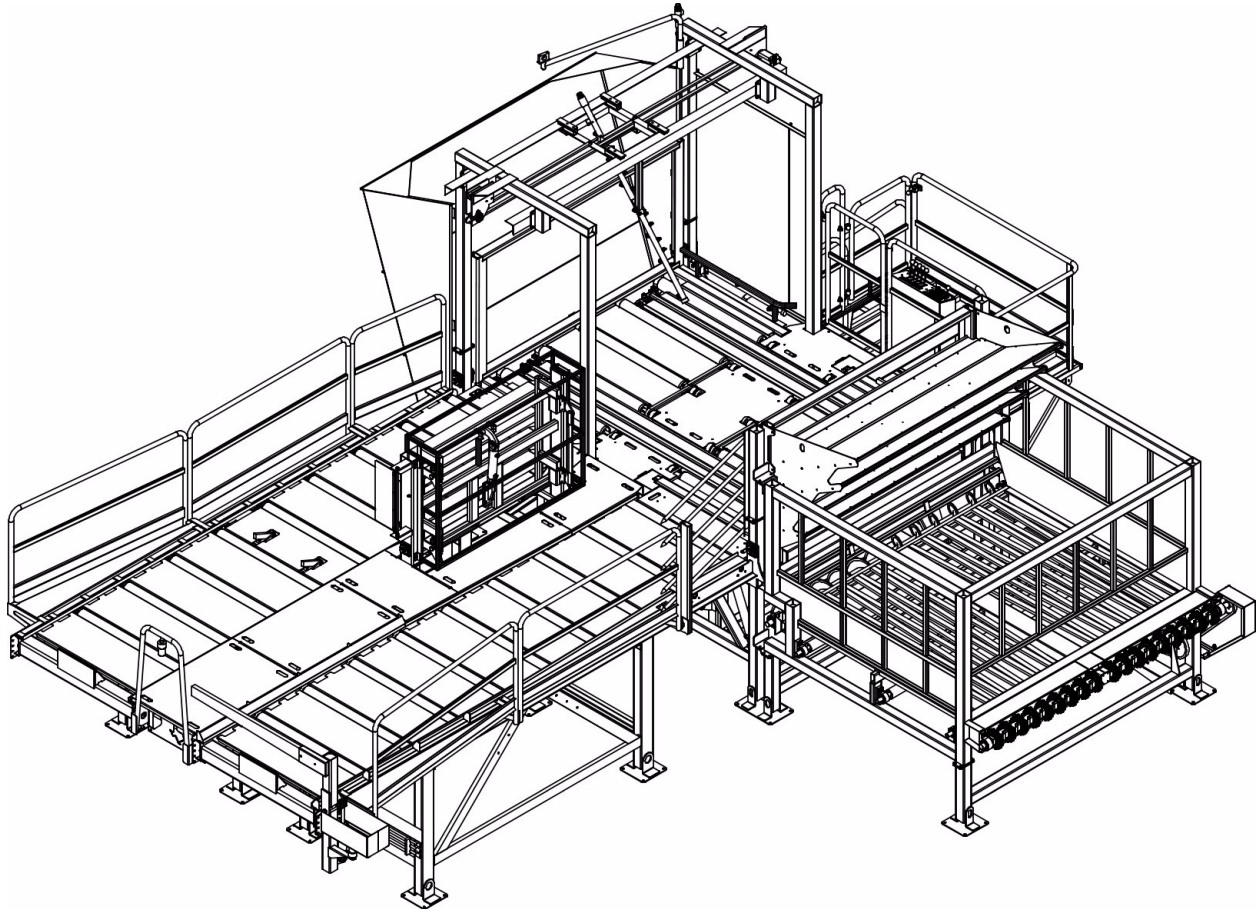

Bright's Cage Unloading System



Operator's & Maintenance Manual

Bright Coop Inc.
803 W. Seale St.
Nacogdoches, TX 75964
Phone (936) 564-8378 Fax (936) 564-3281
Info@brightcoop.com

Printed in the **U.S.A.** 9/18/2013
BC#091-00407



Bright's Cage Unloading System

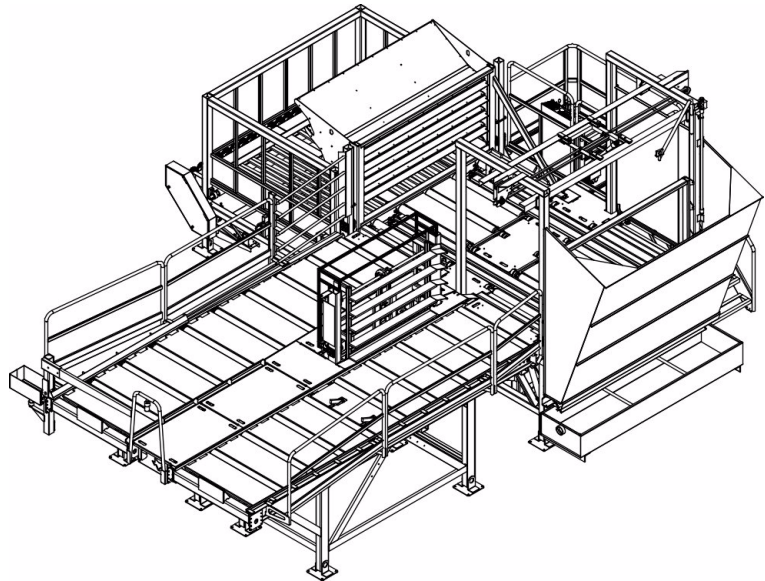
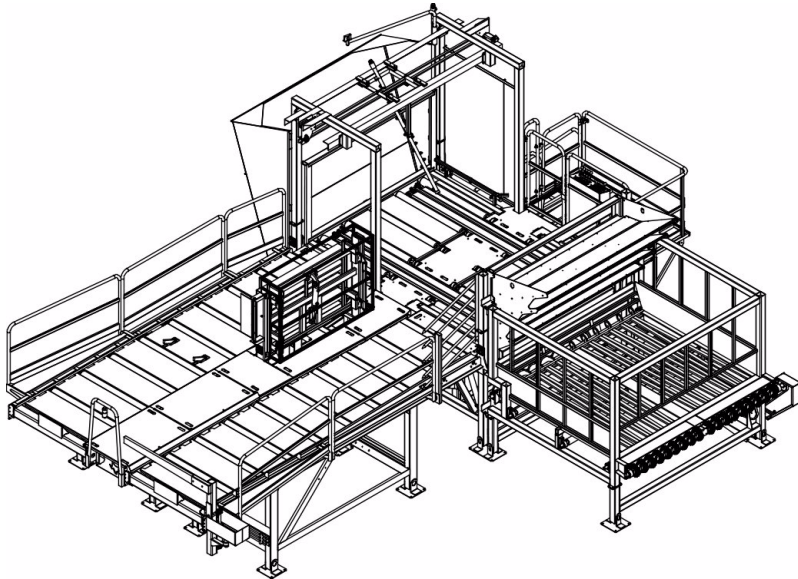

Bright Coop Inc.
803 W. Seale St.
Nacogdoches, TX 75964
Phone (936) 564-8378 Fax (936) 564-3281
Info@brightcoop.com



Bright's Cage Unloading System

Table of Contents

CONFIGURATION	4
QUICK REFERENCE	5
IMPORTANT! PRECAUTIONS & DANGERS	7
FOR THE OPERATOR	7
FOR MAINTENANCE PERSONNEL	8
OPERATOR CONSOLE FUNCTIONS & CONTROL	9
OPERATING PROCEDURES.....	19
VISUAL INSPECTION PRIOR TO OPERATION	19
UNLOADING SYSTEM WITHOUT CAGE WASHING SYSTEM	20
UNLOADING SYSTEM WITH CAGE WASHING SYSTEM	28
MAINTENANCE	37
MAINTENANCE SCHEDULE QUICK REFERENCE	44
RECOMMENDED HYDRAULIC FLUID.....	45
WARRANTY AND LIMITATIONS OF LIABILITY	47



Bright's Cage Unloading System

CONFIGURATION

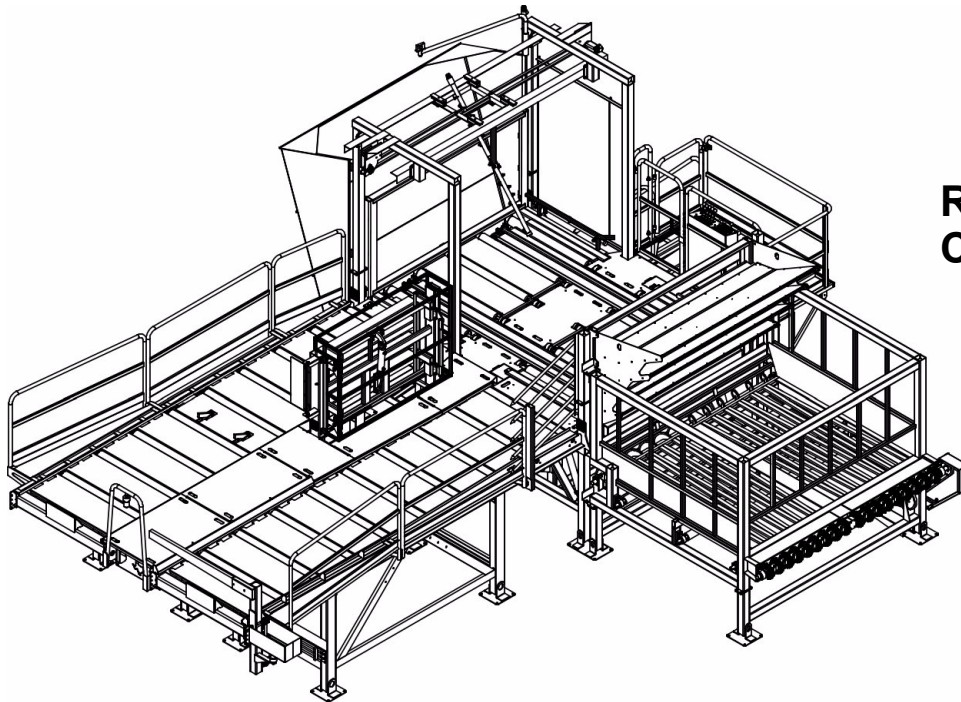

**Right Hand
Configuration**

**Left Hand
Configuration**

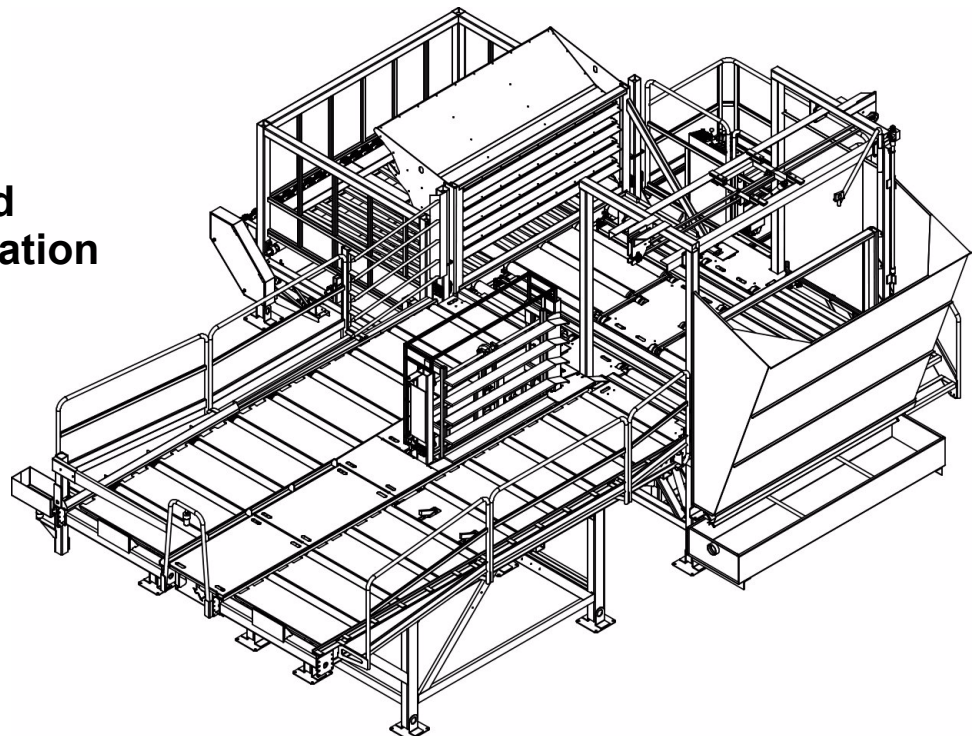



Bright's Cage Unloading System

Quick Reference (Left Hand Side Unloading System Shown)

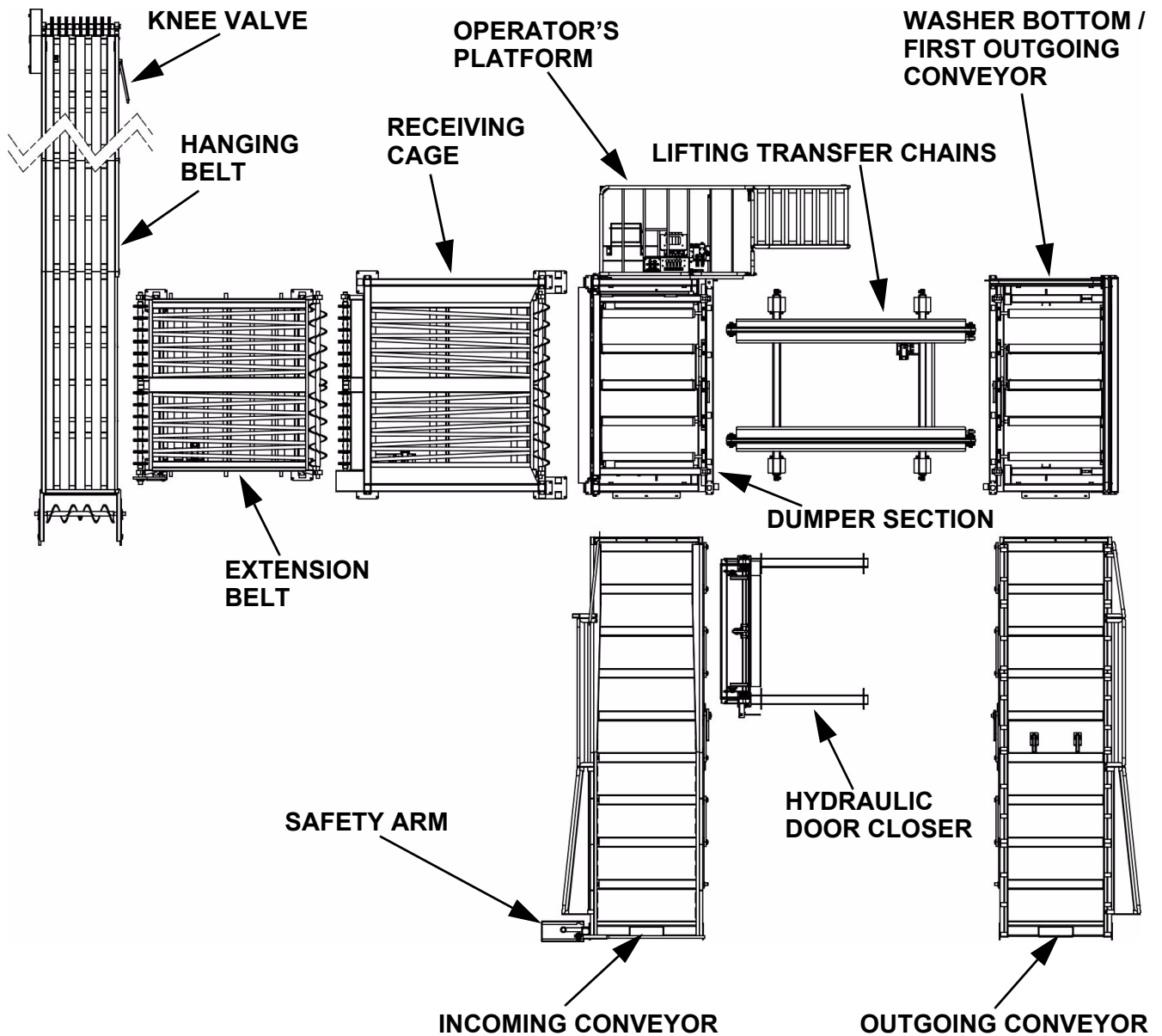



Bright's Cage Unloading System

Study

to Be **Knowledgeable**

Study

to Be **Safe**

Study

for Your **Safety &**

Study

for The **Safety Of Others**



Bright's Cage Unloading System

IMPORTANT! PRECAUTIONS & DANGERS

THE FOLLOWING PRECAUTIONS ARE SUGGESTED TO HELP PREVENT ACCIDENTS. A CAREFUL OPERATOR IS THE BEST OPERATOR. MOST ACCIDENTS CAN BE AVOIDED BY OBSERVING CERTAIN PRECAUTIONS. READ THIS MANUAL AND TAKE THE FOLLOWING PRECAUTIONS BEFORE OPERATING THE CAGE UNLOADING SYSTEM. THE CAGE UNLOADING SYSTEM SHOULD BE OPERATED ONLY BY THOSE WHO ARE RESPONSIBLE AND TRAINED TO DO SO.



FAILING TO FOLLOW SAFETY WARNINGS AND INSTRUCTIONS CAN RESULT IN SERIOUS BODILY INJURY OR EVEN DEATH TO OPERATOR AND/OR OTHERS.

FOR THE OPERATOR

1. Study the operator and maintenance manual thoroughly, and be completely knowledgeable about the operation of the system.
2. Please pay close attention to Safety Warnings posted in various areas of this manual and on the system.
3. Make sure that everyone is clear of the machine, and that nobody is inside the safety fence, at all times. Remember that operator safety and the safety of others rests solely on the operator.
4. Only one (1) operator at a time should be allowed on the operator's platform. Do not allow any other person on the platform at any time.
5. Keep all body parts inside the operator's area.
6. Always shut the master switch "OFF" and remove the key from that switch before leaving the operator platform.
7. Hydraulic fluid is under pressure. DO NOT use hand to check leaks. Use a piece of cardboard or paper. If fluid is injected into skin, obtain medical attention immediately.
8. Never allow children or anyone not properly trained to operate equipment.
9. Always use handrails when walking on the unloading system for any reason.
10. Wear proper attire when operating the system. Loose clothing should not be worn while operating the equipment.
11. Always shut the master switch "OFF" and remove the key from that switch. Then alert your supervisor, and/or the maintenance manager, if any system malfunction occurs.



Bright's Cage Unloading System

FOR MAINTENANCE PERSONNEL

1. Study the operator and maintenance manual thoroughly, and be completely knowledgeable about operation and maintenance of the system.
2. Please pay close attention to Safety Warnings posted in various areas of this manual and on the system.
3. Never attempt to service or maintain the equipment while in operation.
4. Always disconnect the power source to the unloading system (including the hydraulic power unit). Note that proper lockout/tagout procedures must be followed.
5. Always shut master switch "OFF" before performing any service or maintenance.
6. Always lock the cradle before working on and/or underneath the unloading system
7. Always use handrails when walking on the unloading system for any reason.
8. Wear proper attire when performing service or maintenance. Loose clothing should not be worn while servicing or maintaining the equipment.
9. Make sure the master switch is still "OFF" before reconnecting the power source.
10. Make sure that everyone is clear of the machine and/or is outside the safety fence, before turning the master switch "ON" in order to test the equipment.
11. Always shut the master switch "OFF" and remove the key from that switch. Before leaving the operator platform after testing.



DO NOT ATTEMPT TO REMOVE ANY GUARDS WHILE MACHINE IS IN OPERATION. ALWAYS SHUT THE MAIN POWER SOURCE "OFF" AND ADHERE TO THE PROER LOCKOUT/TAGOUT PROCEDURES. ALWAYS REPLACE ALL GUARDS BEFORE ATTEMPTING TO RESTART THE SYSTEM.



ALWAYS ADHERE TO THE CONFINE SPACE PROCEDURES IF YOU HAVE TO WORK UNDERNEATH THE UNLOADING SYSTEM.



Bright's Cage Unloading System

OPERATOR CONSOLE FUNCTIONS & CONTROLS

The operator console is composed of one (1) five (5) section hydraulic control valve, and one (1) electric control panel. Note that the electric panel configurations vary according to options included with your system.

(See figures 3 & 4A & 4B)

OPERATOR CONSOLE

FIGURE 3

RIGHT HAND SIDE SYSTEM (AS OPPOSITE)

REV	REV	DOWN	LEFT	FRWD
INCOMING ROLLS	DUMPER ROLLS	DUMPER TILT	TRANSFER CHAINS	OUTGOING ROLLS
FRWD	FRWD	UP	RIGHT	REV

LEFT HAND SIDE SYSTEM (AS SHOWN)

FRWD	RIGHT	DOWN	RIGHT	REV
OUTGOING ROLLS	TRANSFER CHAINS	DUMPER TILT	DUMPER ROLLS	INCOMING ROLLS
REV	LEFT	UP	LEFT	FRWD

SEE NEXT PAGE
FOR CONTROL PANEL

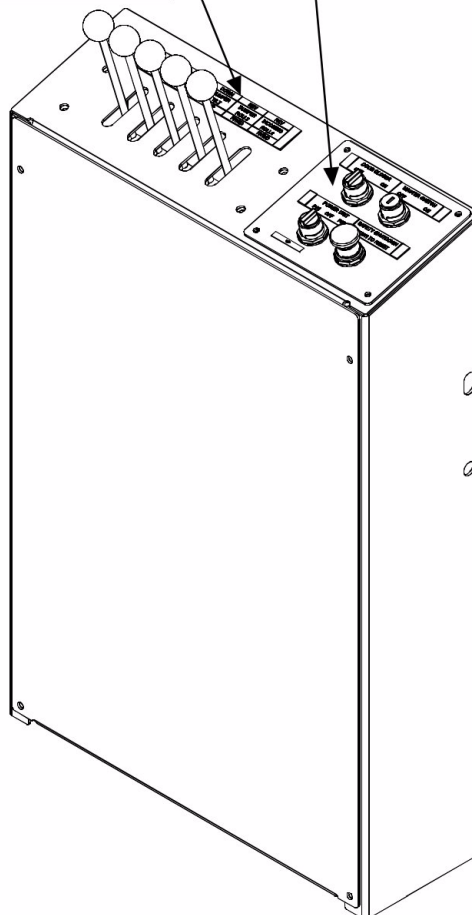



Bright's Cage Unloading System

CONTROL PANEL WITHOUT WASHING SYSTEM

FIGURE 4A

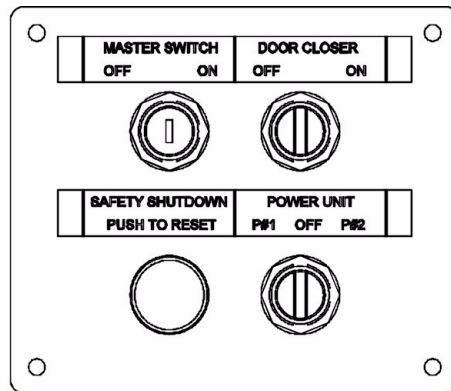
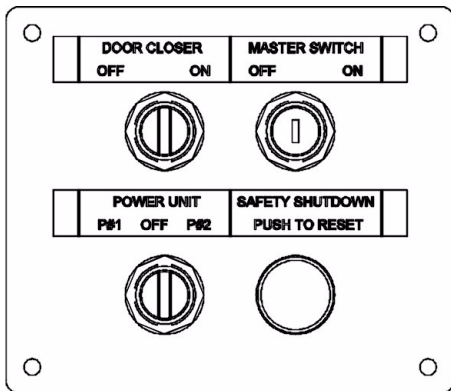

CONTROL PANEL WITH WASHING SYSTEM

FIGURE 4B

LEFT HAND SIDE SYSTEM

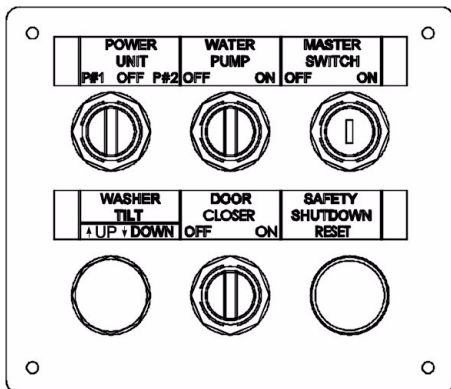

RIGHT HAND SIDE SYSTEM

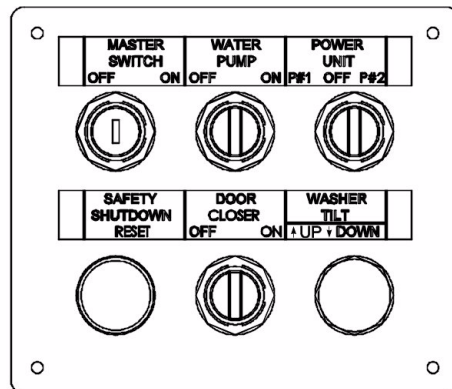



Bright's Cage Unloading System

FUNCTIONS

FIVE (5) SECTION HYDRAULIC CONTROL VALVE

(See figure 3.)

NOTICE

THE FUNCTIONS ARE LAID OUT IN THE SAME ORDER AS THE SYSTEM IS LAID OUT. ALSO, THE ARRANGEMENT CHANGES IF YOU HAVE A LEFT-HAND OR A RIGHT-HAND SYSTEM CONFIGURATION. (See Figure 1 For System Configurations)

⚠ CAUTION

THE ORDER OF THE LEVERS IS GIVEN BY STARTING FROM THE CONTROL PANEL. I.E. FIRST LEVER IS THE CLOSEST TO THE ELECTRIC CONTROL PANEL.

1. FIRST LEVER controls the incoming conveyor rollers. Pulling the lever toward you will move the chicken cage toward the dumper section. Pushing the lever away from you will move the chicken cage away from the dumper section.
2. SECOND LEVER controls the dumper section rollers. Pulling the lever toward you will move the chicken cage onto the dumper section (toward the operator). Pushing the lever away from you will move the chicken cage out of the dumper section and onto the incoming conveyor.

NOTICE

THE OPERATOR MUST PULL OR PUSH LEVERS 1 AND 2 SIMULTANEOUSLY IN ORDER TO MOVE THE CHICKEN CAGE FROM THE INCOMING CONVEYOR TO THE DUMPER SECTION OR THE DUMPER SECTION TO THE INCOMING SECTION RESPECTIVELY.



Bright's Cage Unloading System

3. THIRD LEVER controls the tilt cylinders that operate the cradle on the dumper section. Pulling the lever toward you will lift the cradle and unload the chickens. Note that the cradle should be lifted until the cylinders bottom out, and it should be done without stopping. Pushing the lever away from you will bring the cradle down. Again, hold the lever until the cylinders bottom out.
4. FOURTH LEVER controls the lift transfer chain conveyor. Pulling the lever toward you will lift and move the chicken cage from the dumper section toward the washer section. Pushing the lever away from you will lift and move the chicken cage toward the dumper section.

NOTICE

The operator must release the hydraulic lever as soon as the chicken cage reaches the proper location on the washer section.

Make sure the lifting transfer chain conveyor is down before attempting to move a chicken cage from the incoming conveyor to the dumper section. Doing so may result in lifting chain conveyor damage. (see figure 5)



Bright's Cage Unloading System

LIFT TRANSFER CHAINS

FIGURE 5

DOWN

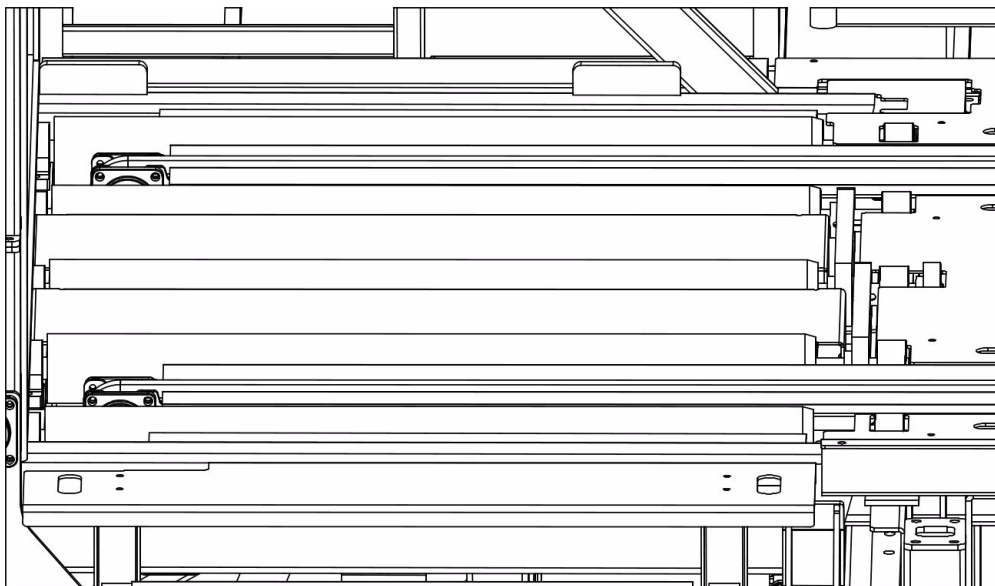

UP

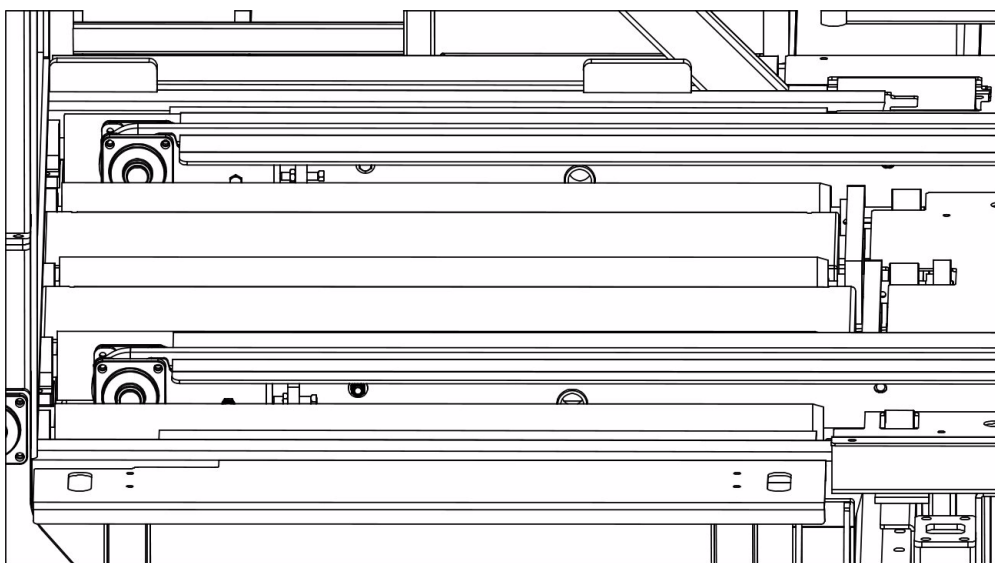



Bright's

Cage Unloading System

5. FIFTH LEVER controls the outgoing conveyor and washer bottom rollers. Pushing the lever away from you will move the chicken cage away from the washer bottom. Pulling the lever toward you will move the chicken cage toward the operator's platform.

NOTICE

THE SPEED OF THE RECEIVING BELT IS CONTROLLED BY THE KNEE VALVE AT THE END OF THE HANGING BELT. IT CAN ONLY BE STOPPED BY TURNING THE HYDRAULIC PUMPING UNIT OFF OR THE MAIN SWITCH OFF.

ELECTRIC CONTROL PANEL

⚠ CAUTION

THE OPERATOR MUST BE FAMILIAR WITH THE CONTROL PANEL IN REGARDS TO THE OPTIONS ON THE UNLOADING SYSTEM.



Bright's Cage Unloading System

UNLOADING SYSTEM WITHOUT CAGE WASHING SYSTEM (See figure 4A)

MASTER SWITCH

- The master switch is a rotary key switch that energizes the whole unloading system (including the hydraulic power unit) when put in the “ON” position.

DOOR CLOSER SWITCH (if equipped)

 **DANGER**

THE DOOR CLOSER IS AN AUTOMATIC DEVICE THAT IS OPERATED BY A HYDRAULIC CYLINDER. DO NOT ATTEMPT TO SERVICE OR MAINTAIN THE DOOR CLOSER UNLESS THE MAIN POWER SOURCE IS NOT ENERGIZED. USE THE PROPER LOCKOUT/TAGOUT PROCEDURES.

- The switch for the door closer must be in the “ON” position for this device to operate. In case of a malfunction, the automatic door closer can be disabled by turning the door closer switch to the “OFF” position.

 **CAUTION**

ALWAYS REPORT ANY MALFUNCTION TO YOUR SUPERVISOR AND/OR THE MAINTENANCE MANAGER.

POWER UNIT SWITCH

- This three (3) position switch turns the pump #1 or pump #2 of the hydraulic power unit “ON” while in the “P#1” or “P#2” position respectively. Both pumps are not energized if the power unit switch is in the “OFF” position.
- We recommend using pump #1 as a primary. Pump #2 should be used one (1) day a week to make sure it is in working condition in case pump #1 fails.



Bright's Cage Unloading System



NEVER ATTEMPT TO SERVICE OR MAINTAIN THE UNLOADING SYSTEM IF THE MAIN POWER SOURCE IS ENERGIZED. USE PROPER LOCKOUT/TAGOUT PROCEDURES.

SAFETY SHUTDOWN RESET BUTTON SWITCH

- The safety shutdown reset push button switch is provided to prevent the system from operating right away when the master power switch is turned “ON” and to reset the safety devices after a safety gate has been opened and closed.
- The operator must depress and release the switch to energize the relays that power all electrical valves. This action must be performed after the master power switch is turned “ON” and after one of the safety gates has been opened and closed.

NOTE: THE OPERATOR MUST WAIT 5 SECONDS AFTER THE MASTER POWER SWITCH IS TURNED “ON”, BEFORE DEPRESSING THE RESET BUTTON SWITCH OR IT WILL NOT RESET THE SYSTEM.



NEVER DEPRESS THE RESET BUTTON SWITCH UNTIL YOU ARE ABSOLUTELY SURE THERE IS NOBODY ON THE UNLOADING SYSTEM AND/OR INSIDE THE SAFETY FENCE.



Bright's Cage Unloading System

UNLOADING SYSTEM WITH CAGE WASHING SYSTEM (See figure 4B)

MASTER SWITCH

- The master switch is a rotary key switch that energizes the whole unloading system (including the hydraulic power unit) when put in the “ON” position.

DOOR CLOSER SWITCH (if equipped)

⚠ DANGER

THE DOOR CLOSER IS AN AUTOMATIC DEVICE THAT IS OPERATED BY A HYDRAULIC CYLINDER. DO NOT ATTEMPT TO SERVICE OR MAINTAIN THE DOOR CLOSER UNLESS THE MAIN POWER SOURCE IS NOT ENERGIZED. USE THE PROPER LOCKOUT/TAGOUT PROCEDURES.

- The switch of the door closer must be in the “ON” position for this device to operate. In case of a malfunction, the automatic door closer can be disabled by turning the door closer switch to the “OFF” position.

⚠ CAUTION

ALWAYS REPORT ANY MALFUNCTION TO YOUR SUPERVISOR AND/OR THE MAINTENANCE MANAGER.

POWER UNIT SWITCH

- This three (3) position switch turns the pump #1 or pump #2 of the hydraulic power unit “ON” while in the “P#1” or “P#2” position respectively. Both pumps are not energized if the power unit switch is in the “OFF” position.
- We recommend using pump #1 as a primary. Pump #2 should be used one (1) day a week to make sure it is in working condition in case pump #1 fails.

⚠ DANGER

NEVER ATTEMPT TO SERVICE OR MAINTAIN THE UNLOADING SYSTEM IF THE MAIN POWER SOURCE IS ENERGIZED. USE PROPER LOCKOUT/TAGOUT PROCEDURES.



Bright's Cage Unloading System

SAFETY SHUTDOWN RESET BUTTON SWITCH

- The safety shutdown reset push button switch is provided to prevent the system from operating right away when the master power switch is turned “ON” and to reset the safety devices after a safety gate has been opened and closed.
- The operator must depress and release the switch to energize the relays that powered all electrical valves. This action must be performed after the master power is turned “ON” and after one of the safety gates has been opened and closed.

NOTE: THE OPERATOR MUST WAIT 5 SECONDS AFTER THE MASTER POWER SWITCH IS TURNED “ON”, BEFORE DEPRESSING THE RESET BUTTON SWITCH OR IT WILL NOT RESET THE SYSTEM.



NEVER DEPRESS THE RESET BUTTON SWITCH UNTIL YOU ARE ABSOLUTELY SURE THERE IS NOBODY ON THE UNLOADING SYSTEM AND/OR INSIDE THE SAFETY FENCE.

WATER PUMP SWITCH

- The two (2) position rotary switch is used to disable the water pump of the cage washing system if a malfunction occurs. This switch should be in the “ON” position in order for the pump of the washing system to operate.

WASHER TILT JOYSTICK

- The cradle of the washer section is tilted upward by pulling the joystick toward you. Note that the cradle must be tilted until the hydraulic cylinders bottom out. When the cradle is completely up, the washing cycle will initiate automatically.
- The cradle of the washer section is tilted downward by pushing the joystick away from you. Note that the cradle must be tilted downward until the hydraulic cylinders bottom out.



Bright's Cage Unloading System

OPERATING PROCEDURES

VISUAL INSPECTION PRIOR TO OPERATION

1. The operator should visibly inspect the hanging belt to make certain the knee valve is not activated and no foreign objects or obstructions are between the belts, and there is not any damage to cause the belt to be unsafe.
2. Operator should also visually check all other belts for foreign objects, obstructions, or damaged parts that would cause the system to be unsafe to operate.
3. The operator should visually check under and around the unloading system to make sure that nobody is on and/or under it and/or inside the safety fence before attempting to energize the system.
4. During the visual inspection the operator should be aware of any oil leaks or damaged parts. If leaks or damaged parts are found, they should be reported to the supervisor and/or the maintenance manager. The system should not be operated until it has been repaired.



THE OPERATOR SHOULD ALWAYS BE AWARE OF ALL SAFETY FEATURES, HOW THEY OPERATE AND REPORT TO THE SUPERVISOR ANYTIME ANYTHING IS FOUND TO BE UNSAFE.



Bright's Cage Unloading System

OPERATING PROCEDURES FOR

UNLOADING SYSTEM WITHOUT CAGE WASHING SYSTEM



NEVER ATTEMPT TO OPERATE THE UNLOADING SYSTEM IF YOU ARE NOT ON THE OPERATOR'S PLATFORM. KEEP ALL BODY PARTS INSIDE THE OPERATOR'S AREA AT ALL TIMES WHILE OPERATING THE UNLOADING SYSTEM.

1. On the control panel, insert the key in the master switch and then turn clockwise to the "ON" position. (See Figure 4A For Switch Location)

Note that the following should occur:

- You should hear an audible alarm.
- You should see two (2) red lights flashing.
- A safety arm should go down on the incoming conveyor. If the safety arm does not go down, make sure the power unit switch is in the "P#1" (pump 1) or "P#2" (pump 2) position. If it is in the "OFF" position, turn it to the "P#1" (pump 1) or "P#2" (pump 2) position. The safety arm should go down if the power unit is in the "P#1" (pump 1) or "P#2" (pump 2) position and the master switch is in the "ON" position. If the safety arm does not go down at this time, turn the master switch "OFF", remove the key, and report the issue to your supervisor and/or the maintenance manager.



NEVER OPERATE THE UNLOADING SYSTEM IF ANY OF THE SAFETY DEVICES ARE DEFECTIVE.

2. If your system is equipped with an automatic hydraulic door closer, make sure the door closer switch on the control panel is in the "ON" position. If not, turn it "ON" at this time.
3. If all of the safety devices are working properly, push and release the safety shutdown reset button on the control panel. After you push and release the button, the audible alarm and the two (2) red flashing lights should stop, and the safety arm should go up.



Bright's Cage Unloading System

4. Test the safety gate switches as follows:
 - Open and close the operator safety gate. After you have performed this action, the safety arm should go down, the audible alarm should sound, and the two (2) red lights should be flashing. If one (1) or more of the safety devices does not work, turn the master switch “OFF”, remove the key, and report the malfunction to your supervisor and/or the maintenance manager. If all safety devices are working properly, push and release the safety shutdown reset button. After you push and release the button, the audible alarm and the two (2) red flashing lights should stop, and the safety arm should go up.
 - With the help of another person (helper), ask the helper to open and close the gates of the safety fence. Note: Open one (1) gate at a time and reset the system between each test.



MAKE SURE YOUR HELPER OR ANYBODY ELSE IS NOT INSIDE THE SAFETY FENCE BEFORE YOU RESET THE SAFETY DEVICE.

5. After the operator gate and the three (3) or more safety fence gates have been tested and proven to work properly, the unloading cycle can begin.



IF ONE (1) OR MORE SAFETY GATE SWITCHES ARE NOT WORKING PROPERLY, TURN THE MASTER SWITCH “OFF”, REMOVE THE KEY, AND REPORT THE MALFUNCTION TO YOUR SUPERVISOR AND/OR THE MAINTENANCE MANAGER.



MAKE SURE THE DUMPER SECTION CRADLE IS NOT LOCKED BEFORE OPERATING THE SYSTEM. (See Figure 6) IF YOU TRY TO OPERATE THE CRADLE WHILE IT IS LOCKED, IT WILL DAMAGE THE EQUIPMENT. UNLESS YOU HAVE AN INTERLOCK SYSTEM THAT SHUTS THE HYDRAULIC PRESSURE OFF AT THE 5 SECTION VALVE.



Bright's Cage Unloading System

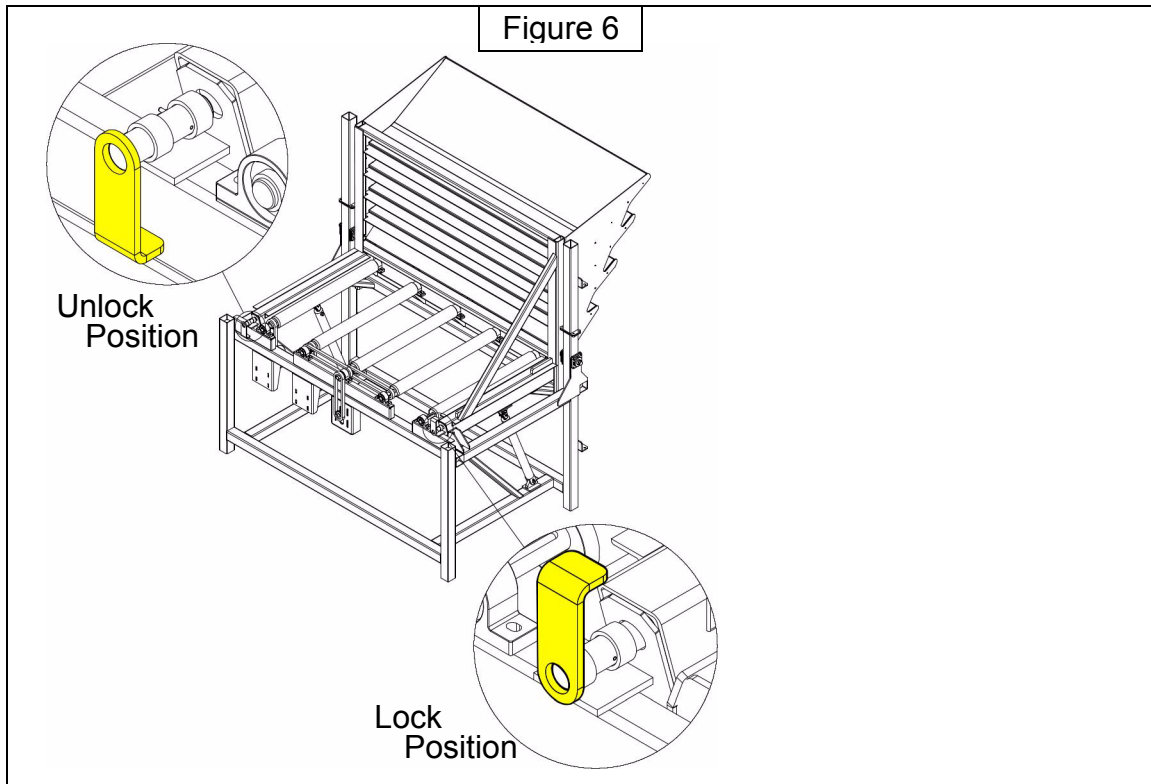

- Note that the standard unloading system as shown may contain up to six (6) chicken cages at a time. Three (3) chicken cages on the incoming side and three (3) chicken cages on the outgoing side.
After the safety device has been reset and the safety arm is up, the forklift operator can set a loaded chicken cage at the end of the incoming conveyor. (See Figure 7)

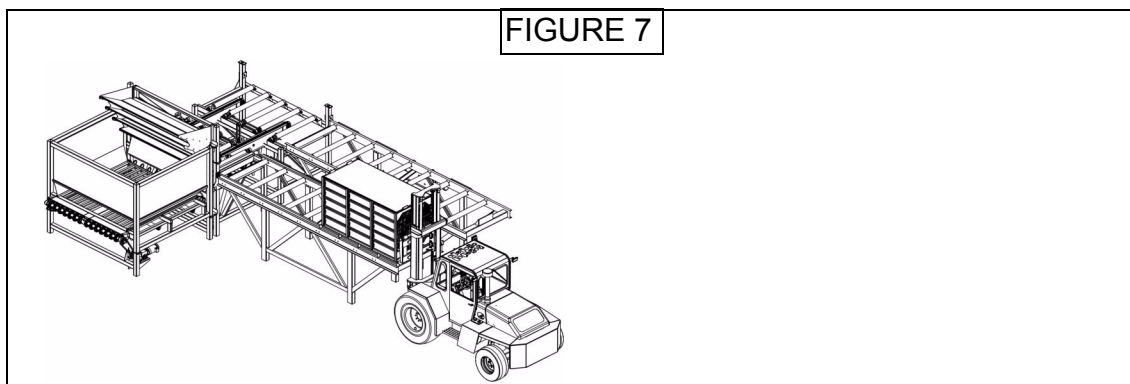



Bright's Cage Unloading System

7. After the chicken cage is set at the loading area on the incoming conveyor, the unloading system operator may pull and hold the first (INCOMING ROLLS) and second (DUMPER ROLLS) hydraulic levers simultaneously. This action will move the loaded chicken cage onto the dumper section. The operator can release the two (2) levers when the cage has reached the stop. (See Figure 8)

NOTICE

THE OPERATOR SHOULD RELEASE THE LEVER PARTIALLY WHEN THE CAGE IS CLOSE TO THE STOP. THIS WILL SLOW THE LOADED CHICKEN CAGE DOWN PRIOR TO REACHING THE STOP AND CONSEQUENTLY WILL MAKE THE SYSTEM AND CHICKEN CAGES LAST LONGER.

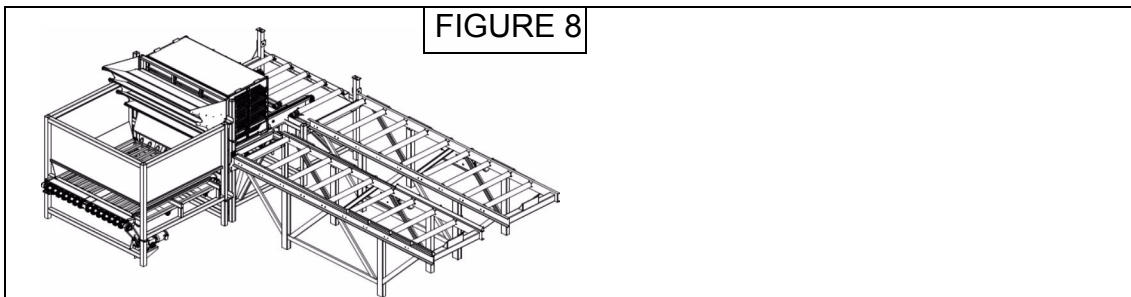

8. As soon as a loaded chicken cage is set on the incoming conveyor, the unloading system operator should move that chicken cage toward the dumper section. This will empty the loading area and the forklift operator will be able to set another loaded chicken cage onto the incoming conveyor and make a continuous flow. (See Figure 9) Note that the unloading system operator should only pull the first (INCOMING ROLLS) hydraulic lever to move the chicken cage toward the dumper section when another chicken cage is already on the dumper section.



Bright's Cage Unloading System

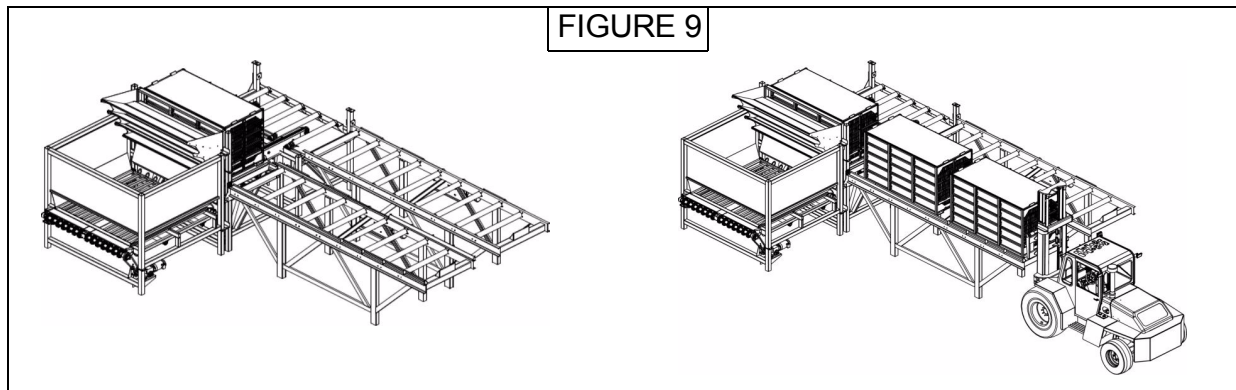

INSTRUCT THE FORKLIFT OPERATOR TO NEVER SHOVE A CHICKEN CAGE FROM THE LOADING AREA TO SET ANOTHER LOADED CAGE ON THE INCOMING CONVEYOR. (See Figure 10) THE FORKLIFT OPERATOR SHOULD ALWAYS WAIT TILL THE UNLOADING SYSTEM OPERATOR MOVES IT.

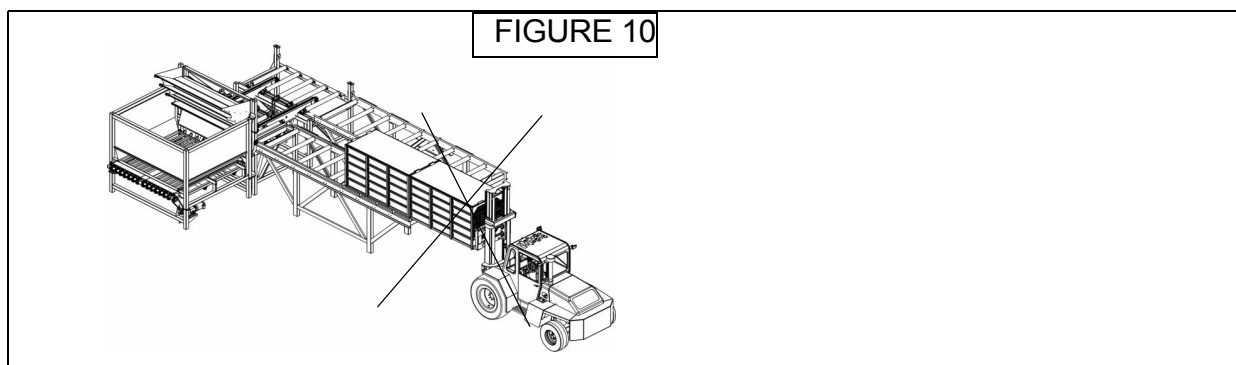

9. Pull the third (DUMPER TILT) hydraulic lever and hold it until the cradle cylinders are fully extended. The cylinders are fully extended when the cradle stops tilting upward. Then release the lever. (See Figure 11)



Bright's Cage Unloading System

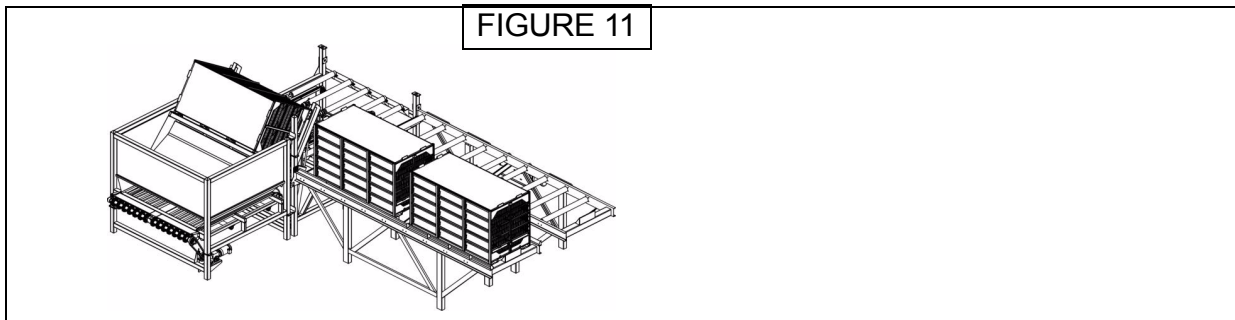

10. Wait about 10 to 15 seconds and push the third (DUMPER TILT) hydraulic lever and hold it until the cradle cylinders are fully retracted. The cylinders are fully retracted when the cradle stops tilting downward. Then release the lever. (See Figure 12)

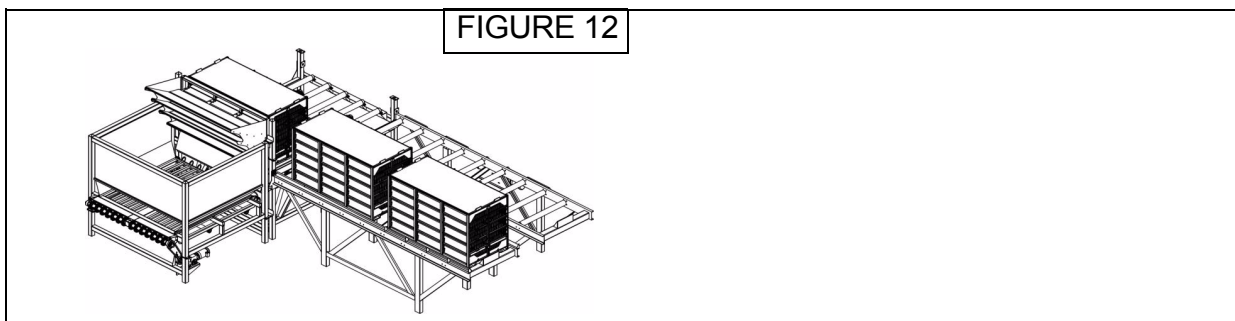

11. Pull fourth (LIFTING TRANSFER CHAIN CONVEYOR) hydraulic lever and hold until the chicken cage transfers to the washer bottom section. As soon as the empty chicken cage is positioned in front of the outgoing conveyor, release the lever immediately.



NEVER ATTEMPT TO SET A LOADED CHICKEN CAGE ON THE DUMPER SECTION WHILE THE LIFTING CHAIN CONVEYOR IS IN THE UP POSITION. THIS MAY RESULT IN DAMAGE TO THE CONVEYOR. (See Figure 13)



Bright's Cage Unloading System

LIFT TRANSFER CHAINS

FIGURE 13

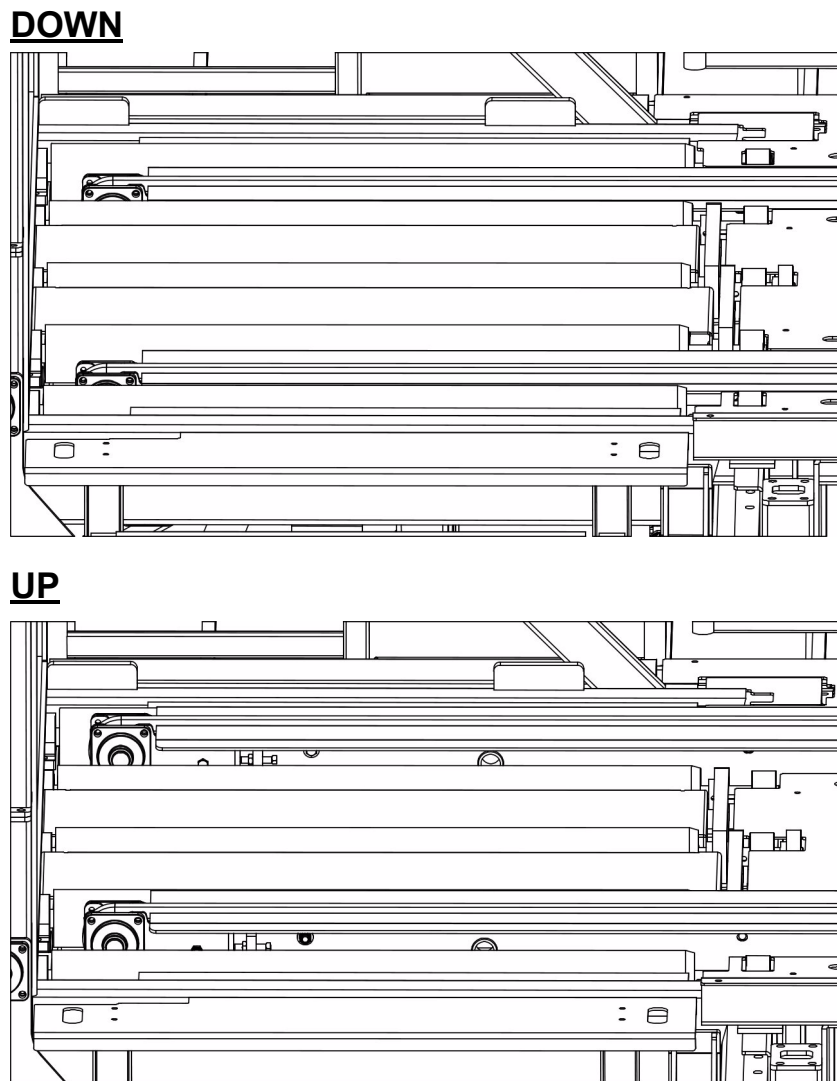

12. At this point, step 7 may be repeated simultaneously with the following. Pull the fifth (OUTGOING ROLLS) hydraulic lever and hold until the empty chicken cage reaches the end of the outgoing conveyor. Then release it. If there is a chicken cage at the unloading area, release the lever before the cages hit each other. Note that if your system is equipped with a hydraulic door closer, you do not have to perform any action. The door closer is an automatic system.



Bright's Cage Unloading System



IF YOUR SYSTEM IS NOT EQUIPPED WITH A DOOR CLOSER, THE DOORS SHOULD BE CLOSED AFTER THE EMPTY CHICKEN CAGE HAS BEEN REMOVED FROM THE UNLOADING SYSTEM.

13. The forklift operator can remove the empty cage from the outgoing conveyor at this time. (See Figure 14)

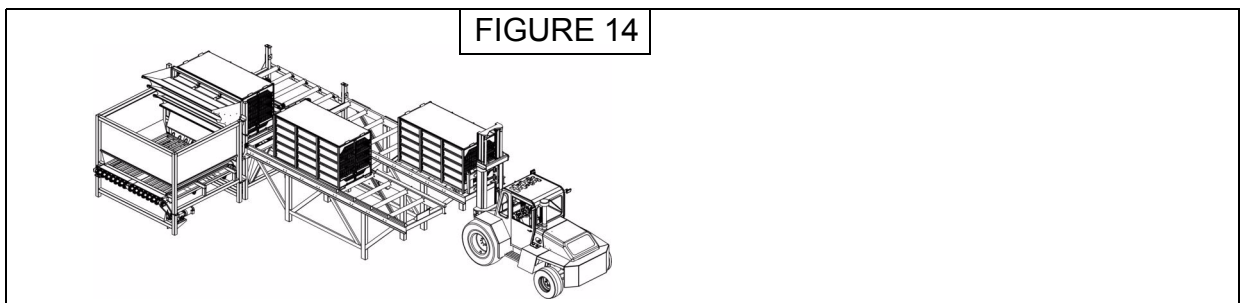

NOTE: For efficiency, the forklift operator should use the following steps.

1. Get a loaded chicken cage from the trailer.
2. Set the loaded chicken cage on the incoming conveyor.
3. Get the empty chicken cage from the outgoing conveyor.
4. Set the empty chicken cage on the trailer.
5. Repeat from step 1.



Bright's Cage Unloading System

OPERATING PROCEDURES FOR UNLOADING SYSTEM WITH CAGE WASHING SYSTEM



NEVER ATTEMPT TO OPERATE THE UNLOADING SYSTEM IF YOU ARE NOT ON THE OPERATOR'S PLATFORM. KEEP ALL BODY PARTS INSIDE THE OPERATOR'S AREA AT ALL TIMES WHILE OPERATING THE UNLOADING SYSTEM.

1. On the control panel, insert the key in the master switch and then turn clockwise to the "ON" position. (See Figure 4B For Switch Location)

Note that the following should occur:

- You should hear an audible alarm.
- You should see two (2) red lights flashing.
- A safety arm should go down on the incoming conveyor. If the safety arm does not go down, make sure the power unit switch is in the "P#1" (pump 1) or "P#2" (pump 2) position. If it is in the "OFF" position, turn it to the "P#1" (pump 1) or "P#2" (pump 2) position. The safety arm should go down if the power unit is in the "P#1" (pump 1) or "P#2" (pump 2) position and the master switch is in the "ON" position. If the safety arm does not go down at this time, turn the master switch "OFF", remove the key, and report the issue to your supervisor and/or the maintenance manager.



NEVER OPERATE THE UNLOADING SYSTEM IF ANY OF THE SAFETY DEVICES ARE DEFECTIVE.

2. If your system is equipped with an automatic hydraulic door closer, make sure the door closer switch on the control panel is in the "ON" position. If not, turn it "ON" at this time.
3. Turn the water pump switch to the "ON" position.
4. If all of the safety devices are working properly, push and release the safety shutdown reset button on the control panel. After you push and release the button, the audible alarm and the two (2) red flashing lights should stop, and the safety arm should go up.



Bright's Cage Unloading System

5. Test the safety gate switches as follows:
 - Open and close the operator safety gate. After you have performed this action, the safety arm should go down, the audible alarm should sound, and the two (2) red lights should be flashing. If one (1) or more of the safety devices does not work, turn the master switch “OFF”, remove key, and report the malfunction to your supervisor and/or the maintenance manager. If all safety devices are working properly, push and release the safety shutdown reset button. After you push and release the button, the audible alarm and the two (2) red flashing lights should stop, and the safety arm should go up.
 - With the help of another person (helper), ask the helper to open and close the gates of the safety fence. Note: Open one (1) gate at a time and reset the system between each test.



MAKE SURE YOUR HELPER OR ANYBODY ELSE IS NOT INSIDE THE SAFETY FENCE BEFORE YOU RESET THE SAFETY DEVICE.

6. After the operator gate and the three (3) or more safety fence gates have been tested and proven to work properly, the unloading cycle can begin.



IF ONE (1) OR MORE SAFETY GATE SWITCHES ARE NOT WORKING PROPERLY, TURN THE MASTER SWITCH “OFF”, REMOVE KEY, AND REPORT THE MALFUNCTION TO YOUR SUPERVISOR AND/OR THE MAINTENANCE MANAGER.



MAKE SURE THE DUMPER SECTION CRADLE IS NOT LOCKED BEFORE OPERATING THE SYSTEM (See Figure 6) IF YOU TRY TO OPERATE THE CRADLE WHILE IT IS LOCKED, IT WILL DAMAGE THE EQUIPMENT. UNLESS YOU HAVE AN INTERLOCK SYSTEM THAT SHUTS THE HYDRAULIC PRESSURE OFF AT THE 5 SECTION VALVE.



Bright's Cage Unloading System

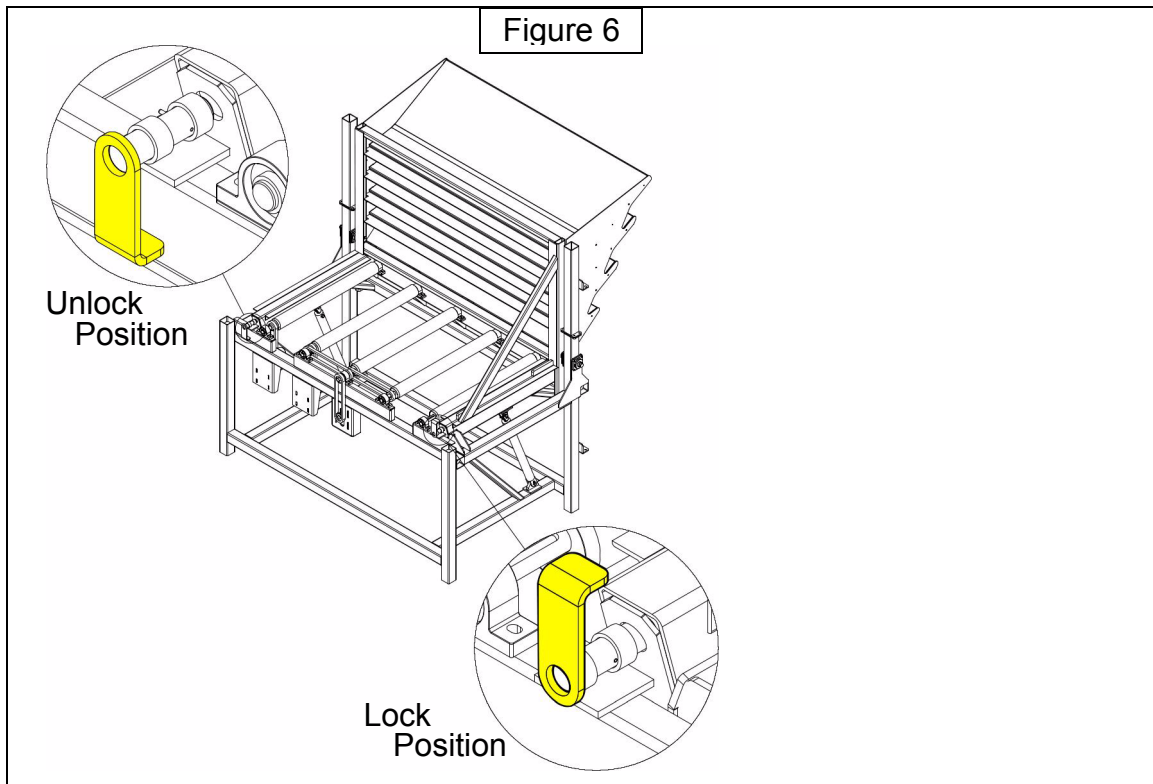

7. Note that the standard unloading system as shown may contain up to six (6) chicken cages at a time. Three (3) chicken cages on the incoming side and three (3) chicken cages on the outgoing side. After the safety device has been reset and the safety arm is up, the forklift operator can set a loaded chicken cage at the end of the incoming conveyor. (See Figure 7)

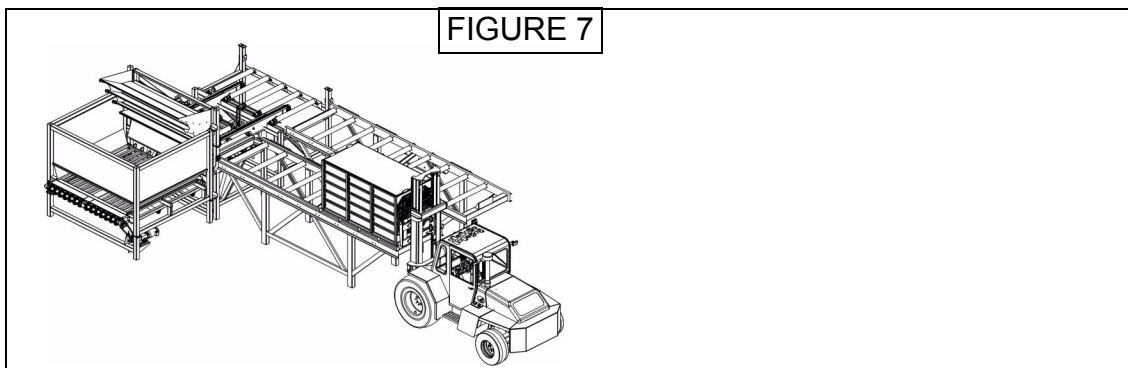



Bright's Cage Unloading System

8. After the chicken cage is set at the loading area on the incoming conveyor, the unloading system operator may pull and hold the first (INCOMING ROLLS) and second (DUMPER ROLLS) hydraulic levers simultaneously. This action will move the loaded chicken cage onto the dumper section. The operator can release the two (2) levers when the cage has reached the stop. (See Figure 8)

NOTICE

THE OPERATOR SHOULD RELEASE THE LEVER PARTIALLY WHEN THE CAGE IS CLOSE TO THE STOP. THIS WILL SLOW THE LOADED CHICKEN CAGE DOWN PRIOR TO REACHING THE STOP AND CONSEQUENTLY WILL MAKE THE SYSTEM AND CHICKEN CAGES LAST LONGER.

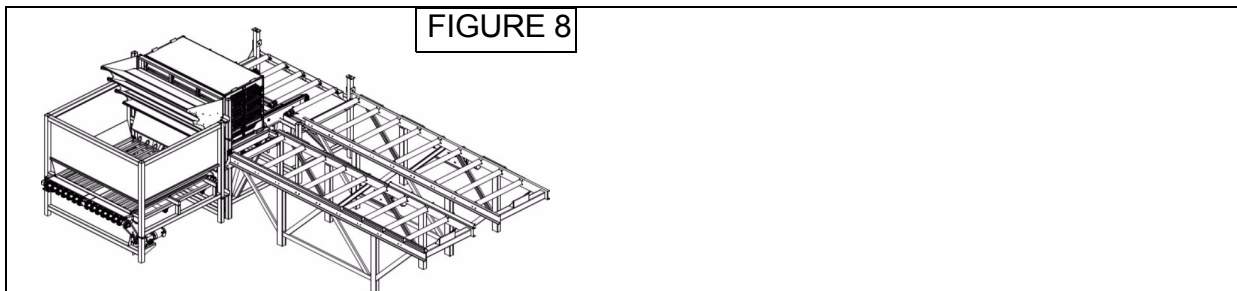

9. As soon as a loaded chicken cage is set on the incoming conveyor, the unloading system operator should move that chicken cage toward the dumper section. This will empty the loading area and the forklift operator will be able to set another loaded chicken cage onto the incoming conveyor and make a continuous flow. (See Figure 9) Note that the unloading system operator should only pull the first (INCOMING ROLLS) hydraulic lever to move the chicken cage toward the dumper section when another chicken cage is already on the dumper section.



Bright's Cage Unloading System

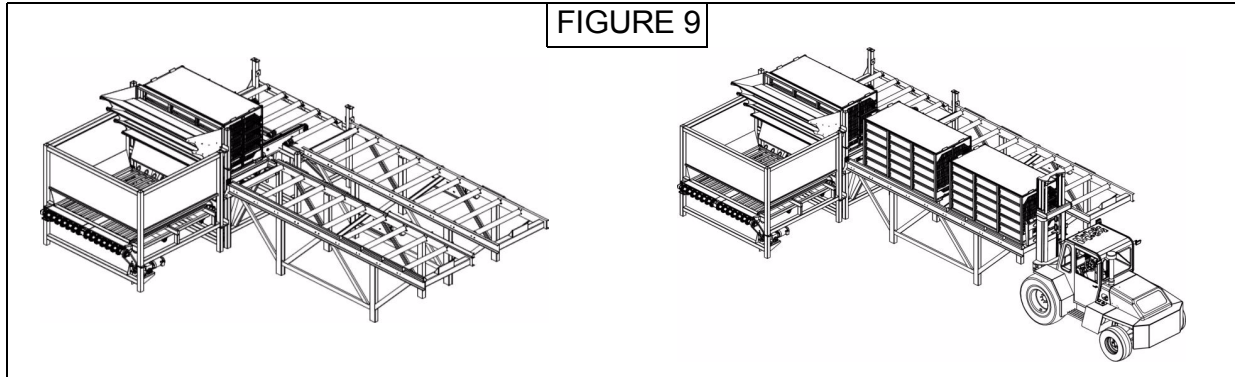

INSTRUCT THE FORKLIFT OPERATOR TO NEVER SHOVE A CHICKEN CAGE FROM THE LOADING AREA TO SET ANOTHER LOADED CAGE ON THE INCOMING CONVEYOR. (See figure 10) THE FORKLIFT OPERATOR SHOULD ALWAYS WAIT TILL THE UNLOADING SYSTEM OPERATOR MOVES IT.

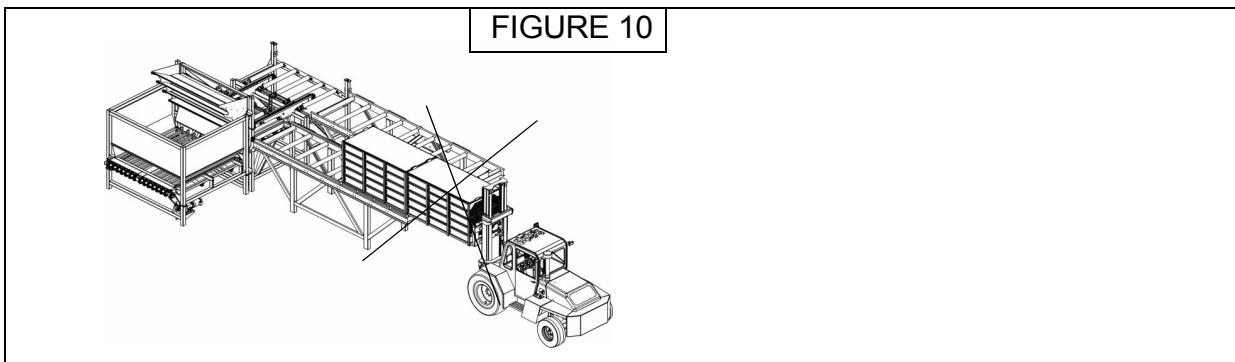



Bright's Cage Unloading System

10. Pull the third (DUMPER TILT) hydraulic lever and hold it until the cradle cylinders are fully extended. The cylinders are fully extended when the cradle stops tilting upward. Then release the lever. (See Figure 11)

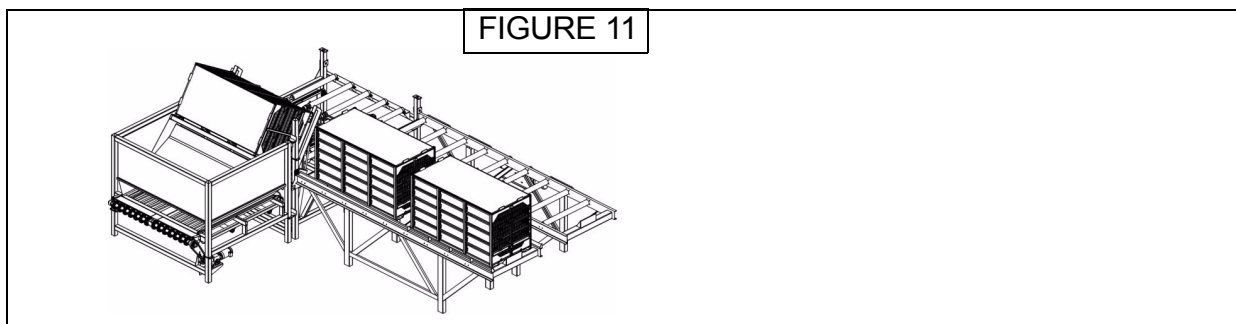

11. Wait about 10 to 15 seconds and push the third (DUMPER TILT) hydraulic lever and hold it until the cradle cylinders are fully retracted. The cylinders are fully retracted when the cradle stops tilting downward. Then release the lever. (See Figure 12)

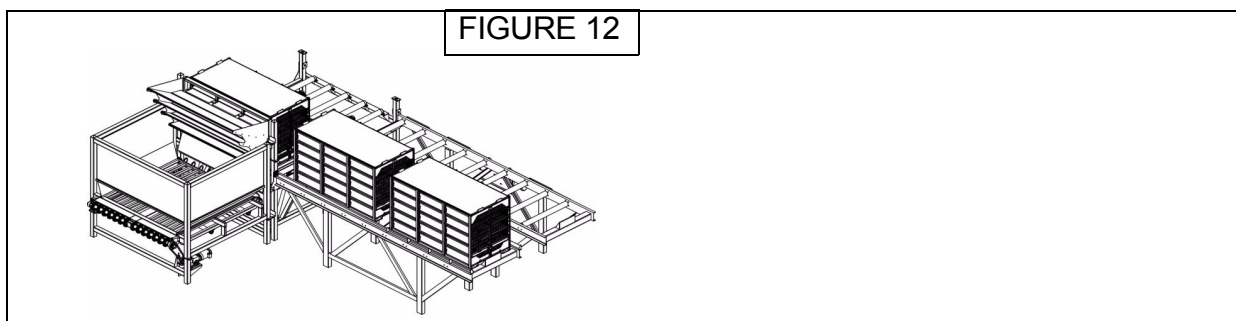

12. Pull fourth (LIFTING TRANSFER CHAIN CONVEYOR) hydraulic lever and hold until the chicken cage transfers to the washer bottom section. As soon as the empty chicken cage reaches the washer cradle, release the lever immediately.



Bright's Cage Unloading System

⚠ CAUTION

NEVER ATTEMPT TO SET A LOADED CHICKEN CAGE ON THE DUMPER SECTION WHILE THE LIFTING CHAIN CONVEYOR IS IN THE UP POSITION. THIS MAY RESULT IN DAMAGE TO THE CONVEYOR. (See Figure 13)

LIFT TRANSFER CHAINS

FIGURE 13

DOWN

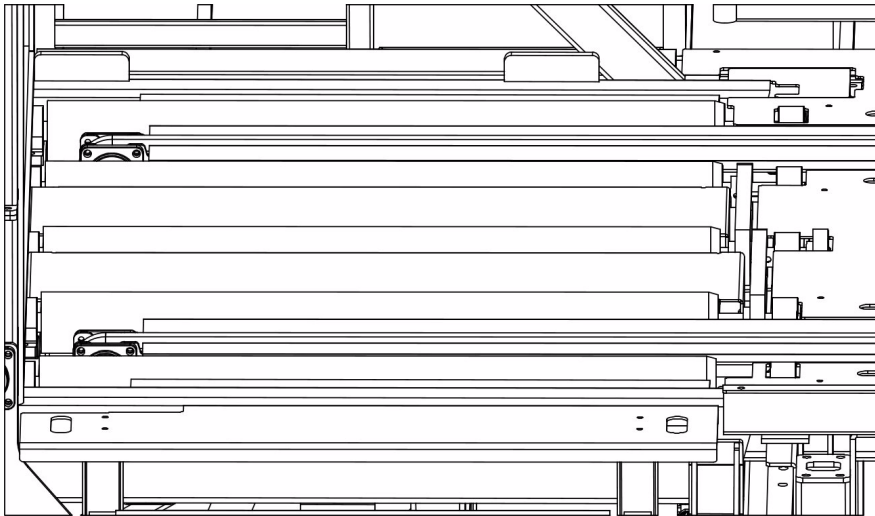

UP

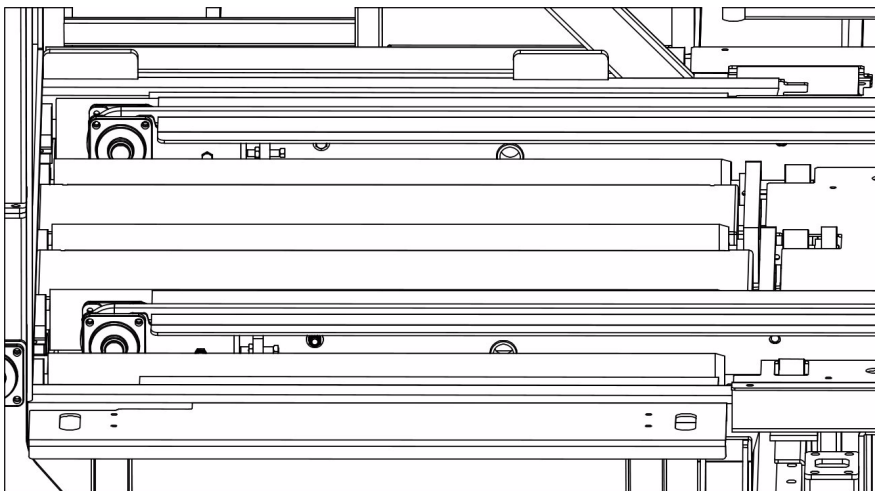



Bright's Cage Unloading System

13. At this time step 7 may be repeated.
14. Pull the washer tilt joystick to raise the washer cradle. Make sure you hold the joystick until the cylinders are fully extended. This will be accomplished when the cradle stops tilting upward while still holding the joystick. Then release the joystick.
15. The washing cycle start automatically when the cradle reaches the upper position. This cycle lasts around one (1) minute. If the washing cycle does initiate, but no water is coming out of the nozzles, verify that the water pump switch is in the "ON" position. If the switch is in the "OFF" position, turn it to the "ON" position. If the switch is in the "ON" position, but no water is coming out of the nozzles, turn the water pump switch "OFF" and report the malfunction to your supervisor and/or the maintenance manager.
16. After the washing cycle is completed. Push and hold the washer tilt joystick until the cradle is completely down. This will be accomplished when the cradle stops tilting downward while still holding the joystick. Then release joystick.
17. Pull the fifth (OUTGOING ROLLS) hydraulic lever and hold until the empty chicken cage reaches the end of the outgoing conveyor. Then release it. If there is a chicken cage at the unloading area, release the lever before the cages hit each other

Note that if your system is equipped with a hydraulic door closer, you do not have to perform any action. The door closer is an automatic system.



IF YOUR SYSTEM IS NOT EQUIPPED WITH A DOOR CLOSER, THE DOORS SHOULD BE CLOSED AFTER THE EMPTY CHICKEN CAGE HAS BEEN REMOVED FROM THE UNLOADING SYSTEM.



Bright's Cage Unloading System

18. The forklift operator can remove the empty cage from the outgoing conveyor at this time. (See Figure 14)

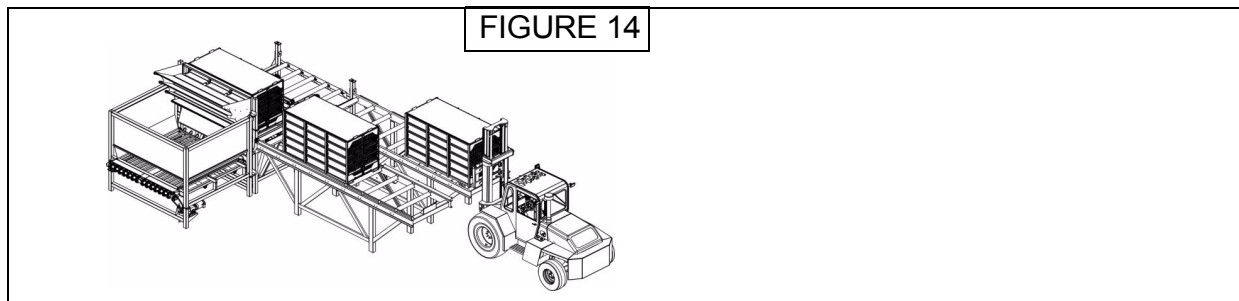

NOTE: For efficiency, the forklift operator should use the following steps.

1. Get a loaded chicken cage from the trailer.
2. Set the loaded chicken cage on the incoming conveyor.
3. Get the empty chicken cage from the outgoing conveyor.
4. Set the empty chicken cage on the trailer.
5. Repeat from step 1.



Bright's Cage Unloading System

MAINTENANCE, UNLOADING SYSTEM

WARNING

ALL MAINTENANCE PERSONNEL THAT IS INTENDED TO WORK ON THE CAGE UNLOADING SYSTEM MUST READ AND UNDERSTAND THIS MANUAL THOROUGHLY BEFORE ATTEMPTING TO DO ANY MAINTENANCE WORK. NOT DOING SO MAY RESULT IN DAMAGE TO THE UNLOADING SYSTEM, SERIOUS INJURIES OR DEATH.

DANGER

MAKE ABSOLUTELY SURE THAT THE UNLOADING SYSTEM IS NOT ENERGIZED BEFORE STARTING TO WASH THE SYSTEM OR DOING ANY OTHER MAINTENANCE TO THE UNLOADING SYSTEM. USE PROPER LOCKOUT/TAGOUT PROCEDURES.

WARNING

ALWAYS ADHERE TO THE CONFINE SPACE PROCEDURES IF YOU HAVE TO WORK UNDERNEATH THE UNLOADING SYSTEM.

DANGER

ALWAYS LOCK THE DUMPER SECTION CRADLE BEFORE WORKING ON AND/OR UNDERNEATH THE UNLOADING SYSTEM. (See Figure 6)

To lock the cradle do the following steps:

- Open the access doors at the end of the cradle lower arms
- Turn the lock handles up.
- Insert the lock pins into the cradle arm ends.
- Close the access doors in order to secure the locks in place.



Bright's Cage Unloading System



ALWAYS UNLOCK THE CRADLE BEFORE RUNNING THE UNLOADING SYSTEM FOR TEST, AFTER ANY MAINTENANCE OR REPAIRS. IF THE LOCK REMAINS IN THE LOCK POSITION, AND THE DUMPER TILT LEVER IS ACTIVATED, THE CRADLE WILL BE DAMAGED. UNLESS YOU HAVE AN INTERLOCK SYSTEM THAT SHUTS THE HYDRAULIC PRESSURE OFF AT THE 5 SECTION VALVE.

GENERAL

- Pressure wash the entire unloading system daily. When pressure washing the entire unloading system, be on alert to detect any discrepancies while washing the system. If any discrepancies are found, take note in order to make the repair after the washing process is completed.
- Grease all bearings and bushings weekly.
- Lubricate all drive chains weekly.

SAFETY DEVICES

Verify that all safety devices are working properly every week. We recommend using the following steps to ensure that they are working properly.



MAKE ABSOLUTELY SURE THAT NOBODY IS ON AND/OR UNDER THE UNLOADING SYSTEM. ALSO MAKE SURE NOBODY IS INSIDE THE SAFETY FENCE AND ALL SAFETY GATES ARE CLOSED BEFORE ENERGIZING THE UNLOADING SYSTEM.

1. Turn the main power source "ON".
2. From the operator's platform, insert the key into the master switch and turn it to the "ON" position. At this time you should hear an audible alarm and see two (2) red lights flashing. Also, if the power unit switch is in the "P#1" or "P#2" position, you should see a safety arm at the end of the incoming conveyor coming down. If the power unit switch is in the "OFF" position, turn it to the "P#1" position.
3. If all the safety devices are working properly, go to step 7.
4. If one or more of these devices malfunction, turn the master switch to the "OFF" position. Remove the key from the master switch. Then turn the main power source "OFF"



Bright's Cage Unloading System



MAKE SURE YOU ADHERE TO THE PROPER LOCKOUT/TAGOUT PROCEDURES BEFORE GOING TO STEP 5.

5. Repair any safety devices that are malfunctioning and make a note for your maintenance report of the discrepancies.
6. Repeat steps 1 thru 4 until all of the described safety devices are working properly.
7. After all the safety devices described in step 2 are proven to be working properly, push and release the safety shutdown reset switch button.
8. Open and close the operator's safety gate. The audible alarm should sound, two (2) red lights should start flashing, and the safety arm should come down.
9. If the safety devices are activated, push and release the safety shutdown reset button and then go to step 14.
10. If the safety devices were not activated, turn the master switch to the "OFF" position and remove the key from the switch.
11. Turn the main power source "OFF". Always adhere to the proper lockout/tagout procedures.
12. Repair the operator safety gate switch.
13. Start back at step 1.
14. To perform step 14 to 23 you will need a helper that has read and understood this manual.
15. Ask your helper to open and close a safety fence gate. NOTE: Open one (1) gate at a time and reset the system between each test. The audible alarm should sound, two (2) red lights should be flashing, and the safety arm should come down.



MAKE SURE YOUR HELPER OR ANY OTHER PERSON HAS NOT ENTERED THE SAFETY FENCE. IF SOMEBODY HAS ENTERED THE SAFETY FENCE, TURN THE MASTER SWITCH "OFF" IMMEDIATELY AND INSTRUCT THE PERSON(S) TO GO OUTSIDE THE SAFETY FENCE AND CLOSE THE GATE. THEN TURN THE MASTER SWITCH BACK "ON".



Bright's Cage Unloading System

16. If the safety devices are activated, push and release the safety shutdown reset button and go to step 24.
17. If the safety devices are not activated, turn the master key switch to the "OFF" position and remove the key.
18. Turn the main power source "OFF". Always adhere to the proper lockout/tagout procedures.
19. Repair the faulty safety fence gate switch.
20. Turn the main power source "ON".
21. Insert the key into the master switch and turn it to the "ON" position.
22. Push and release the safety shutdown reset button.
23. Repeat from step 15 until all safety gates are proven to work properly.

HYDRAULIC POWER UNIT

24. Verify the power unit oil level every day before energizing the system. (See figure 15) If the hydraulic fluid level is low, add the required amount of clean oil to reach the maximum level. See recommended hydraulic fluid on page 45 for proper type and grade.

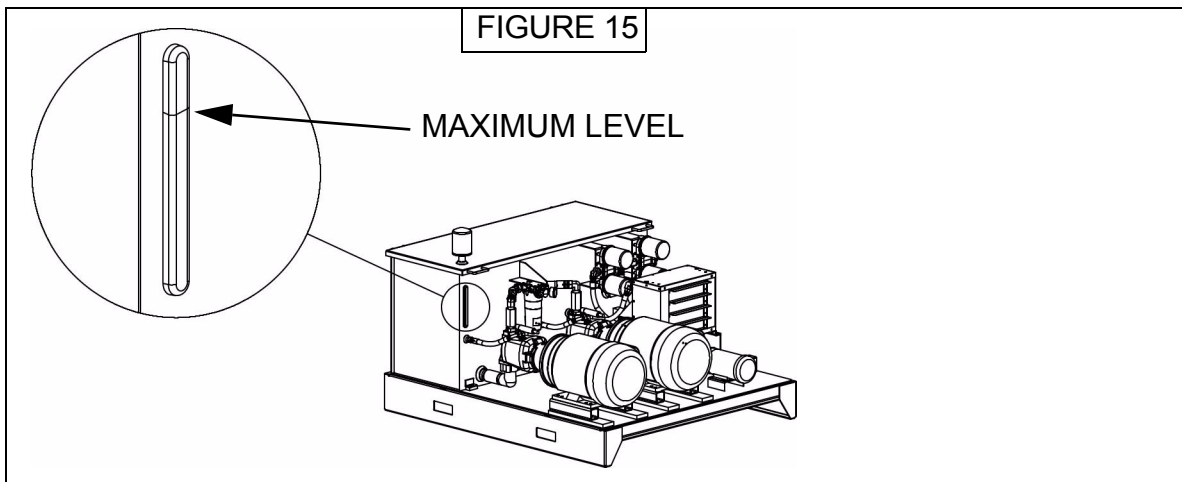



Bright's Cage Unloading System

NOTICE

MAKE SURE NO WATER OR OTHER CONTAMINANTS CAN ENTER THE HYDRAULIC TANK WHILE RAISING THE TANK LID. ALSO, MAKE SURE YOU CLOSE THE LID AFTER YOU HAVE FILLED THE TANK TO THE PROPER LEVEL.

25. Make a visual inspection of the hydraulic power unit and the unloading system for leaks daily. If any leaks are found, it must be repaired immediately.
 - All filters [kidney loop (2), main return (2), and pressure (1)] must be replaced after every 250 hours of operation.
 - Replace the hydraulic fluid once a year.

⚠ WARNING

MAKE SURE YOU DISPOSE OF THE USED OIL AND FILTERS ACCORDING TO YOUR ENVIRONMENTAL STATE LAWS.

LIFTING TRANSFER CHAIN CONVEYOR

⚠ DANGER

ALWAYS ADHERE TO THE PROPER LOCKOUT/TAGOUT PROCEDURES BEFORE ATTEMPTING TO DO ANY MAINTENANCE TO THE UNLOADING SYSTEM.

26. Verify and adjust (if necessary) the tension of the main chain. (See Figure 16)
To adjust the tension of the lifting transfer chains, do the following steps.
 - Loosen the holding bolt.
 - Turn the pushing screws clockwise until you have obtained the desired tension.
NOTE: You have to turn the pushing screws (one on each side) evenly.
 - Tighten the holding bolt.



Bright's Cage Unloading System

TRANSFER CHAIN TAKEUP

FIGURE 16

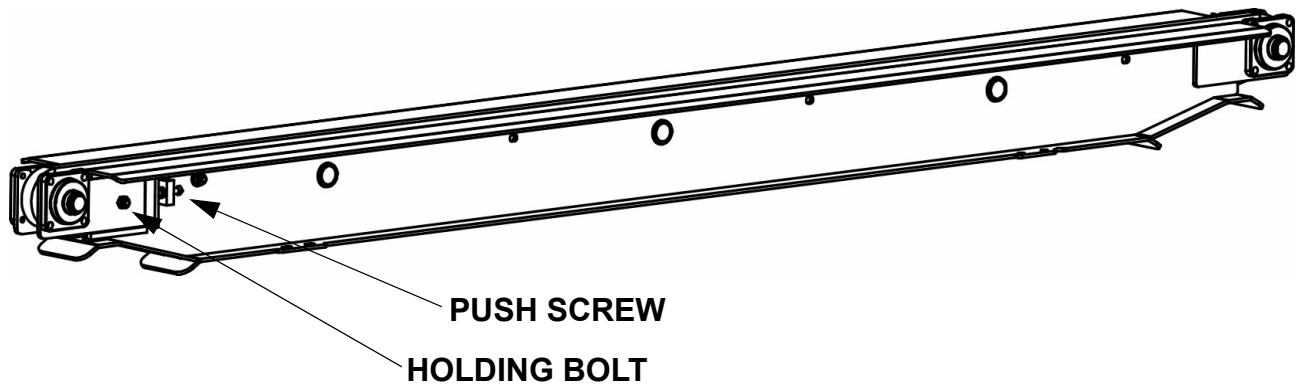

⚠ DANGER

MAKE ABSOLUTELY SURE THAT NOBODY REMAINS ON AND/OR UNDER THE UNLOADING SYSTEM, NOBODY REMAINS INSIDE THE SAFETY FENCE, AND THAT ALL SAFETY GATES ARE CLOSED BEFORE TURNING THE MAIN POWER SOURCE "ON".



Bright's Cage Unloading System

27. Turn the main power source "ON".
28. Insert the key into the master switch and turn it to the "ON" position.
29. Push and release the safety shutdown reset button.
30. Slowly pull the fourth hydraulic lever (LIFT TRANSFER CHAIN) toward you and observe closely if the chains are moving smoothly.
31. If the chains are moving smoothly, go to step 36.
32. If the chains are not moving smoothly, the chains must be tightened properly.
33. Turn the master switch to the "OFF" position and remove the key.
34. Turn the main power source "OFF" and lockout/tagout.
35. Go back to step 26.
36. Turn the master switch to the "OFF" position and remove the key.
37. Turn the main power source "OFF" and lockout/tagout.

 **DANGER**

ALWAYS ADHERE TO THE PROPER LOCKOUT/TAGOUT PROCEDURES.

RECEIVING AND HANGING BELTS

38. With the main power source "OFF" and proper lockout/tagout, inspect the condition of the belts and repair if necessary. This should be performed weekly.

 **DANGER**

MAKE SURE YOU ADHERE TO THE PROPER LOCKOUT/TAGOUT PROCEDURES BEFORE ATTEMPTING ANY MAINTENANCE WORK.

39. Verify the tension of the drive chains and adjust if necessary. This should be performed weekly.



Bright's Cage Unloading System

MAINTENANCE SCHEDULE QUICK REFERENCE

MAINTENANCE SCHEDULE	DAILY	WEEKLY	250 Hrs	MONTHLY	6 MONTHS	YEARLY
	Pressure wash all the system	X				
Hydraulic power unit oil level	X					
Hydraulic leaks	X					
Check unloading system safety devices *		X				
Check & replace any wear-out or bent rollers		X				
Check transfer chain tension & adjust if necessary		X				
Check condition of belts and return rollers		X				
Check general condition & replace damage parts		X				
Lubricate conveyor drive chains		X				
Lubricate transfer chains		X				
Grease bearings		X				
Grease tilt cylinder pivots (Cradles)		X				
Hydraulic filters (Kidney loop, return, pressure)			X			
Pins and rods of belts				X		
Carriage washer sliding blocks					X	
Change hydraulic power unit fluid						X

* The unloading system safety devices are:

- Two (2) red flashing lights
- An audible alarm
- An incoming conveyor safety arm
- An outgoing cage stop
- AN operator gate switch
- Three (3) safety fence gate switches
- Safety fence



Bright's Cage Unloading System

RECOMMENDED HYDRAULIC FLUID

The following list of industrial hydraulic oils is recommended for use in our hydraulic system.

Oils sold by listed suppliers under other trade names, or oils, which are sold by unlisted suppliers, may not be considered to be a satisfactory hydraulic media. Many formulations are being offered which lack certain additives or are formulated for special reasons, such as lower cost, high detergency, leakage control, etc. Some of these specialty fluids can be used successfully; however, others may prompt malfunctions and high rates of wear.

We recommend Viscosity Grade B (medium) unless otherwise specified.

Manufacturer	Fluid Name	Viscosity Grade	Manufacturer	Fluid Name	Viscosity Grade
Argo	Duro AW S-150	A	Lubrication Engineers	Monolec 6110A	B
	Duro AW S-215	B		Monolec 6120A	C
	Duro AW S-315	C			
Ashland	Ultramax AW-15	A	Lubriplate	HO-0	A
	Ultramax AW-20	B		HO-1	B
	Ultramax AW-30	C		HO-2	C
Benz	Petraulic AZ	A	Mobil	DTE 24	A
	Petraulic BZ	B		DTE 25	B
	Petraulic CZ	C		DTE 26	C
Champlin	Hydrol 150	A	Phillips	Magnus A 150	A
	Hydrol 215	B		Magnus A 215	B
	Hydrol 315	C		Magnus A 315	C
Chevron	Chevron HYD 32	A	Shell	Tellus 25	A
	ChevronHYD 46	B		Tellus 29	B
	Chevron HYD 68	C		Tellus 33	C
Cities Service	Pacemaker XD-15	A	Southwest	9640	B
	Pacemaker XD-20	B			
	Pacemaker XD-30	C			
Continental	Super Hydraulic 15	A	Standard Oil Of Ohio	Industron 44	A
	Super Hydraulic 21	B		Industron 48	B
	Super Hydraulic 31	C		Industron 53	C
Exxon	Nuto H 46	B	Sun	Sunvis816 WR	A
	Nuto H 68	C		Sunvis 821 WR	B
Filmite	Industrial 150	A	Texaco	Sunvis 831 WR	C
	Industrial 200	B		Rando HD 46	B
	Industrial 300	C		Rando HD 68	C
Fieke	HO-0	A	Tower	Hydroil AW-3	A
	HO-1	B		Hydroil AW-4	B
	HO-2	C		Hydroil AW-5	C
Gulf	Harmony 46 AW	B	Union	Unax AW 150	A
	Harmony 68 AW	C		Unax AW 215	B
				Unax AW 315	C
Houghton	Hydro-Drive HP150	A	Withrow	Withrolube 655	A
	Hydro-Drive HP200	B		Withrolube 656	B
	Hydro-Drive HP300	C		Withrolube 657	C



Bright's Cage Unloading System



Bright's Cage Unloading System

WARRANTY AND LIMITATIONS OF LIABILITY

COVERAGE PROVIDED

Bright Coop, Inc. (BCI) warrants every part of the cage unloading system manufactured by BCI to be free under normal use and service from defects in material and workmanship. This warranty extends to the original purchaser only and shall continue for a period of 1 year on all components from the date of sale of the original purchaser or date of original use, whichever is earlier. Any such parts proving to be defective within the warranty period may be, at the option of BCI, either repaired or replaced, provided that such defective parts are returned freight prepaid to the BCI factory in Nacogdoches, Texas, and provided further that written notice of such defective parts shall be given to BCI at the address shown above within 10 days of discovery of such defects.

The obligation of BCI to the purchaser under this warranty is limited to the repair or replacement of defective parts, which will cover charges for both parts and labor, using BCI service parts. Repair or replacement in accordance with this warranty shall constitute fulfillment of all liabilities of BCI.

Repairs or replacements will be performed by a qualified BCI technician or may be repaired or replaced by the original purchaser's maintenance personnel as long as the work or replacement is done in accordance with BCI recommendations. If the repair(s) or replacement(s) are done by the original purchaser's maintenance personnel, BCI will reimburse the original purchaser for a reasonable amount of labor involved at the rate of \$30.00 U.S. currency per hour if the original purchaser or authorized employee of the original purchaser mails or faxes a copy of the repair details which includes the date of original sale, the serial number of the unit to be repaired, a description of failure, causal part, the nature of the defect and obtain a Repair Authorization from BCI.

ITEMS NOT COVERED BY THIS WARRANTY

1. Parts not manufactured by BCI are not covered by this warranty and any warranty on such parts is limited to that extended by the original equipment manufacturer of such parts.
2. This warranty shall not apply:
 - a. If the cage unloading system has been subject to misapplication, abuse, misuse, negligence, fire or other accident;
 - b. If parts not made or supplied by BCI have been used in connection with the cage unloading system, if in the sole judgment of BCI such use affects its performance or reliability;
 - c. If the cage unloading system has been altered or repaired in a manner which, in the sole judgment of BCI, affects its performance or reliability;
 - d. To incidental charges such as, travel time, delivery charges, hydraulic oil, lubricants, to normal replacement of service items (such as filters), or to normal deterioration due to use or exposure (such as exterior finish);
 - e. Unless all safety devices and guards provided with the equipment are properly installed and used in this operation and unless there is compliance with all operating procedures and maintenance instructions as set forth in the instructional and operating manuals furnished by BCI;
 - f. To any cage unloading system if its serial number has been altered, defaced or removed, or if payment for the cage unloading system is in default.

DISCLAIMER OF IMPLIED WARRANTIES AND CONSEQUENTIAL DAMAGES

THERE ARE NO EXPRESSED WARRANTIES COVERING THE CAGE UNLOADING SYSTEM MANUFACTURED BY BCI OTHER THAN AS SET FORTH ABOVE, AND THE WRITTEN WARRANTY IS IN LIEU OF ANY IMPLIED WARRANTIES, INCLUDING ANY IMPLIED WARRANTY OF MERCHANTABILITY OR FITNESS FOR A PARTICULAR PURPOSE. In no event shall BCI be liable for special, incidental or consequential damages or claims therefore, including (but not limited to) damages or claims due to lost profits, lost time, personal injury, or other expenses whether or not resulting directly or indirectly from claimed defects covered by the above written warranty. No person is authorized to make on behalf of BCI any representations beyond those expressed herein.

RIGHT TO MAKE DESIGN CHANGES

Bright Coop, Inc. reserves the right to make changes in the design and other changes in its products at any time and from time to time without notice and without incurring any obligation with respect to any product previously ordered from it, sold or shipped by it.

GENERAL PROVISIONS

All notices, demands, claims or other communications with respect to this written warranty must be addressed to Bright Coop, Inc., 803 W. Seale, Nacogdoches, Texas, 75964.

This warranty shall be interpreted and governed by the laws of the State of Texas.